

PRODUCT GUIDE

AIR POWERED PUMP TECHNOLOGY
MANUFACTURED IN JAPAN



ABOUT YAMADA...



Yamada Europe B.V.

Aquamarijnstraat 50
7554 NS Hengelo
The Netherlands

Phone +31 (0)74-242 2032

Fax +31 (0)74-242 1055

E-mail: sales@yamada-europe.com

Web: www.yamada-europe.com

CONTENTS

Yamada Corporation has been a leading producer of industrial equipment since 1905, and for pneumatic pumps for over 80 years. As a leader in pneumatic pumping technology, Yamada is known in many industries worldwide for its innovative products, superior quality and unmatched reliability. Yamada has an impressive history of delivering new products and solving customer problems which confirm Yamada's position as the industry leader.

Yamada's reputation for manufacturing top quality products, allied with continuing efforts in research and development have created a strong foundation for market leadership. As an ISO 9001 certified corporation, stringent quality procedures are followed throughout the manufacturing process, including liquid testing of every pump prior to shipping.

Yamada Corporation has its primary headquarters in Tokyo, Japan, with manufacturing based in Sagami-hara City. Assembly facilities are located in Chicago, Illinois, USA and Hengelo, The Netherlands; an office in Thailand; and Shanghai is covering the emerging markets of China. These offices are supportcenters for over 400 Yamada distributors worldwide.

Yamada Europe B.V., a wholly owned subsidiary of Yamada Corporation, was established in 1986 to provide sales and service and support for Europe, the Middle East and Africa, through a highly trained network of distributors.

Our professional staff provides:

- Customer service
- Product training
- Research & development
- Parts and service for all Yamada pumps
- Application engineering
- Industry knowledge

With a wide customer network, Yamada is in position to service the global market needs worldwide. Contact Yamada Europe for the closest distributor location.

We build our pumps with quality and innovation. This is the cornerstone of the Yamada design and manufacturing process.

For additional information, product literature, and drawings please visit www.yamada-europe.com or contact our sales team at +31 (0)74-24 220 32.



Engineered to Perform	4
Air Valve Technology	5
Ten Features of a Yamada Diaphragm Pump	6
ATEX	6
Understanding Performance Curves	6
NDP-5 Series Pumps	7
DP-10/15 Series Pumps	8
NDP-15 Series Pumps	10
NDP-(P)20 Series Pumps	12
NDP-(P)25 Series Pumps	14
NDP-40 Series Pumps	16
NDP-(P)50 Series Pumps	18
NDP-80 Series Pumps	20
Dimensional Drawings	22
Global Series	26
G15 Series Pumps	28
G25 Series Pumps	30
High Pressure 2:1 Pumps	32
Manifold Options	32
XDP Series Pumps	33
Powder Series Pumps	33
Drum Kits	34
FDA Compliant Pumps	35
DM(B)(X) Series Pumps	35
FR(L) Units	36
NDP-32 Serie Pump	36
Connection Types	37
Muffler Options	37
Solids Handling Pump	38
Liquid Level Controller	39
Dry-Run Detection	39
Pulsation Dampeners	40
Pump Diaphragms	41
Min/Max Fluid Temperature to Pump	41
Optional Coatings	42
Installation	42
Additional Options	43

ENGINEERED TO PERFORM

Fully bolted leak free mating surfaces

All Yamada pumps incorporate registered fit bolted construction, which simplifies reassembly after maintenance. No leak-prone clamp bands are utilized.

One air valve fits all

The NDP-40, 50 & 80 series pumps utilize one common air valve assembly, reducing parts inventory and assembly confusion. The NDP-20 & 25 have a common air valve as well. One air valve concept is used in all Yamada NDP series pumps!

Outside accessible

Inspection or maintenance of every Yamada air valve can be performed without removing the pump from service.

Pilot valve

Unique design is an individual modular pilot valve that actuates the air valve. It is maintenance-free, with no cumbersome snap rings or lubricated dynamic o-rings to replace or repair.

Diaphragm dynamics

Extensive research has led to the development of an optimal stroke length that maximizes diaphragm life and performance while minimizing downtime and maintenance costs.

NDP-series plastic pumps are made of reinforced plastic composite, what helps to reduce the fluctuations in torque values of the bolts to the minimum. It simplifies the assembly with actual torque values and has a positive influence on reducing the leak paths.

NDP-series PVDF and POM pumps are made of conductive PVDF and POM, what allows to use them in ATEX environments.

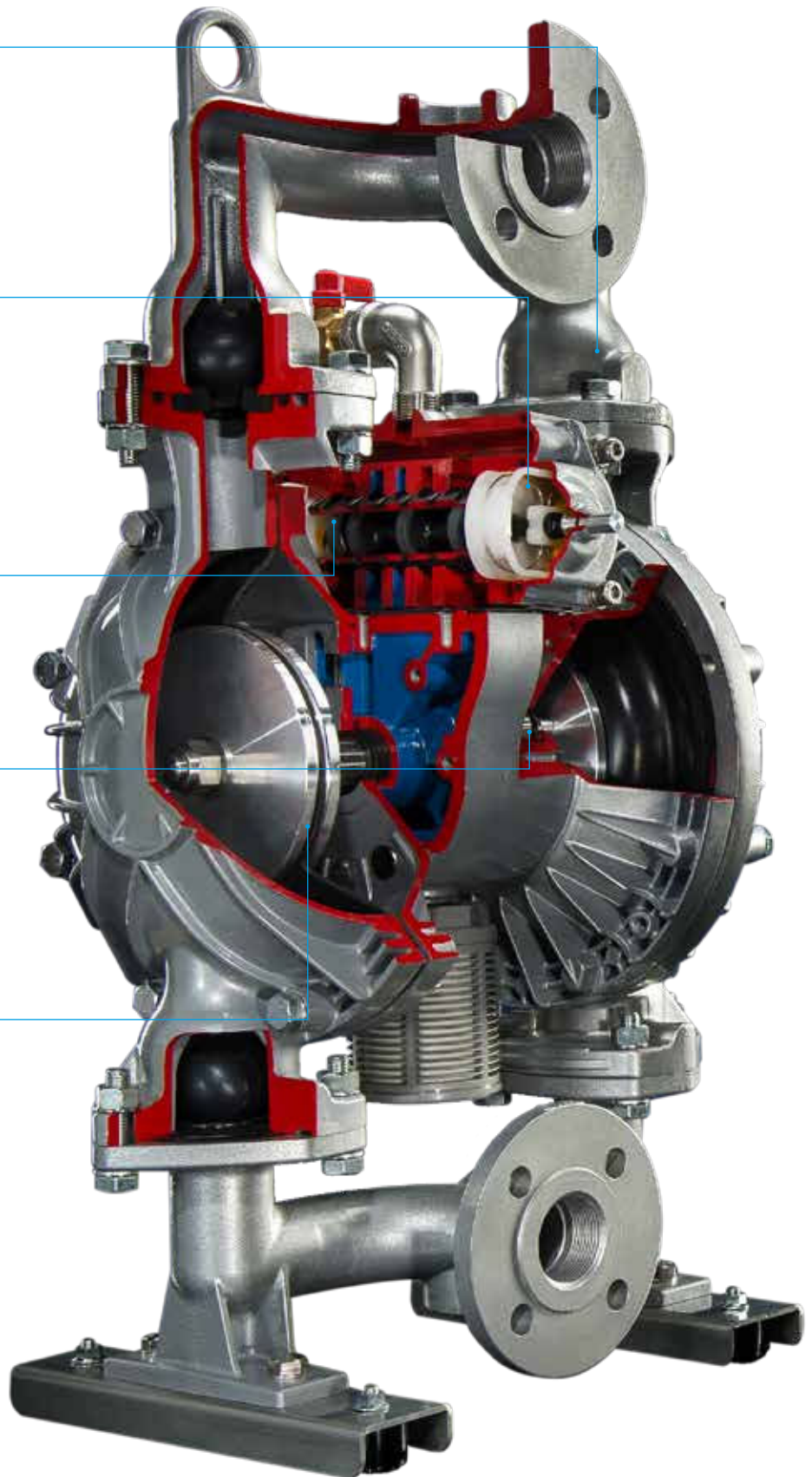

BUILT TO LAST

AIR VALVE TECHNOLOGY



Air valve technology is the heart of the air-powered double diaphragm pump and determines reliability.

Unified Air Valve Concept

To simplify, Yamada offers two common size air valve assemblies within five sizes of pumps (3/4" & 1" pumps and 1-1/2" 2" & 3" pumps) further reducing reassembly confusion and parts inventory. We try to unify to reduce multiple air valve designs and revisions. Whether your pumps are functioning continuously or intermittently; at high or low pressure; using dirty or clean air, Yamada offers one field proven design.

Truly Non-Lubricated Air Valve

The patented air valve on all NDP series pumps never requires lubrication or pre-packing. The advanced design eliminates the need for external lubrication which can lead to pumpage contamination and maintenance headaches. Yamada is proud to be the originator of non-lubricated air valve technology for air-powered double diaphragm pumps.

Component Replaceable

All Yamada air valves can be restored with individual components, without requiring complete valve and housing replacement.

Non-Stalling

A patented non-centering, spring-assisted shifter is incorporated into every NDP Series pump, ensuring a positive shift every time.

The 304 stainless steel C-springs provide exceptional durability and longevity and are tested to last over **300 million cycles!** The spring assist also aides in long dead head (closing a valve in the discharge without closing the air pressure) applications for reliable startup.

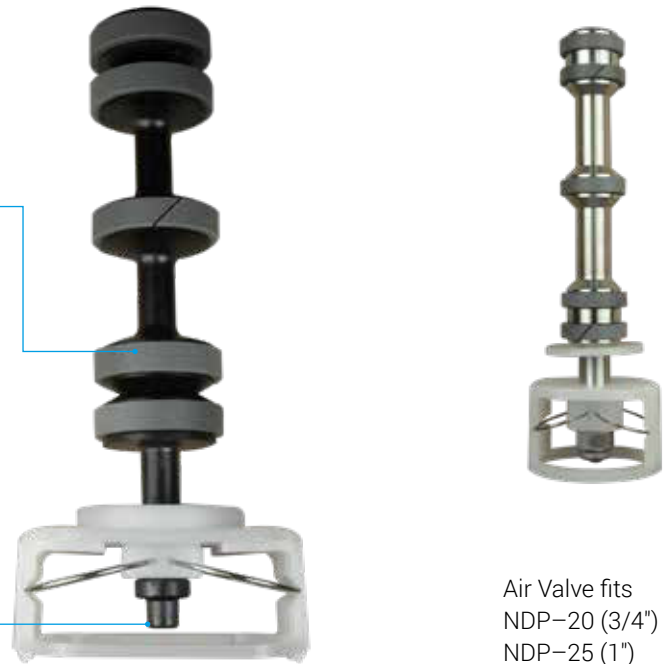

Common-size air valve assemblies reduce parts confusion.

Air Valve fits
NDP-20 (3/4")
NDP-25 (1")
Series Pumps

Air Valve fits
NDP-40 (1-1/2")
NDP-50 (2")
NDP-80 (3")
Series Pumps



For additional information on Yamada products and services, visit www.yamada-europe.com

TEN FEATURES OF A YAMADA DIAPHRAGM PUMP

1. Handles a wide variety of fluids with high solids content: No close fitting or rotating parts so liquid with high solids content and/or size can be easily pumped.
2. Self Priming: The Yamada pump design (incorporating internal check valves) allows for high suction lift even at dry start-up and with heavier fluids.
3. Ability to run dry: No close fittings or sliding parts are at risk—the pump can run dry without damage.
4. Variable flow rate and discharge pressure: Yamada pumps will run at any setting within their operating range simply by adjusting the air inlet pressure and system conditions. One pump can fit a broad spectrum of applications.
5. Portable/Simple Installation: Yamada pumps transport easily to the application site. Simply connect your air supply line and liquid lines; the pump is ready to perform. There are no complex controls to install and operate.
6. Dead Head: Because the discharge pressure can never exceed air inlet pressure, the discharge line can be closed with no damage or wear. The pump will simply slow down and stop.
7. Shear Sensitive: The gentle nature and minimal parts contact with the liquid makes Yamada pumps an excellent choice for shear sensitive fluids.
8. Explosion Proof: Yamada pumps are operated by compressed air, therefore, they are intrinsically safe.
9. Submersible: If external components are compatible—Yamada pumps can be submerged in the liquid by simply running the exhaust line above the liquid level.
10. Pumping efficiency remains constant: There are no rotors, gears, or pistons, which wear over time and lead to the gradual decline in performance/flow rate.

For additional information on Yamada products & services, visit www.yamada-europe.com.

ATEX

Yamada offers also pumps and dampeners according ATEX 114 Explosion safety guidelines. For additional information please contact our sales team at +31 (0)74-24 220 32



UNDERSTANDING PERFORMANCE CURVES

To determine compressed air requirements and proper size for a Yamada Air-powered Double Diaphragm Pump, two elements of information are required:

1. Required Flow Rate (l/min or GPM)
2. Total Dynamic Head (back pressure)

10 m water height is 1 Bar (0,1 MPa) back pressure.

As an example, consider an NDP-40 Series Pump with rubber diaphragms performance curve. Pump pumping at 250 l/min (66 GPM) (I) at 10 m (33 Feet) (—) back pressure.

Point “●” on the performance curve is where the desired Flow Rate (l/min or GPM) and Total Dynamic Head points intersect. This point determines compressed air requirements for the particular pump.

At performance point “●”, the pump will require approximately 3 Bar (0,3MPa or 45 PSI) air inlet pressure.

To arrive at this figure, follow the solid curve (—) to the left to read the air pressure rating in MPa.

By looking at the dashed line (---), it is determined the pump will require approximately 1500 l/min of air volume.

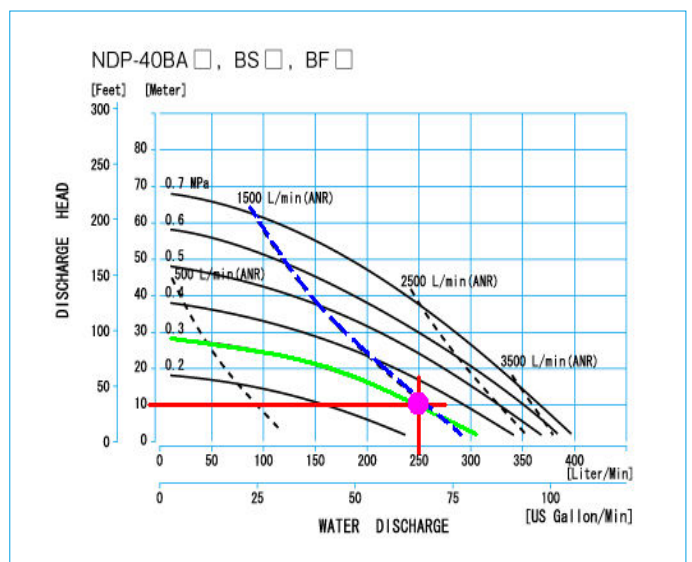

0,1 MPa	= 1 Bar
1 Bar	= 14,5 PSI
1 l	= 0,26 Gallon (gal.)
1 m	= 3,28 Feet (ft.)
1 m ³ /h	= 0,58 SCFM
1000 l/min	= 34 SCFM
SCFM	= Standard Cubic Feet Per Minute

NDP-5 SERIES

Maximum Capacity 11 l/min
Port Size 1/4" (6 mm)



NDP-5 Polypropylene

Dimensions:
154 mm W x 147 mm H
Net Wt.: 1,3 kg

NDP-5 Conductive Kynar®

Dimensions:
154 mm W x 147 mm H
Net Wt.: 1,7 kg



NDP-5 Conductive Acetal

Dimensions:
154 mm W x 147 mm H
Net Wt.: 1,4 kg



NDP-5 Stainless Steel

Dimensions:
155 mm W x 149 mm H
Net Wt.: 2,7 kg



NDP-5 Aluminum

Dimensions:
155 mm W x 149 mm H
Net Wt.: 1,6 kg

NDP-5 SPECIFICATIONS

Port Dimensions

Intake & discharge connection:	1/4" 6 mm Female Rc
Air inlet (incl. ball valve):	1/4" 6 mm Female Rc
Air exhaust (internal silencer):	3/8" 10 mm Female Rc

Air Supply Pressure (All Models)

2,0– 7,0 Bar (0,2 – 0,7 MPa)

Discharge Volume Per Cycle

20 mL

Maximum Suction Lift: 1,0 m

Air Motor

Standard: Ryton® air motor

Model Number Nomenclature

Polypropylene (PPG)	NDP-5FPT
Conductive Kynar® (PVDF)	NDP-5FVT
Conductive Acetal (POM)	NDP-5FDT
Aluminum (ADC-12)	NDP-5FAT
Stainless Steel (SCS14)	NDP-5FST

NDP-5 serie Performance Curve

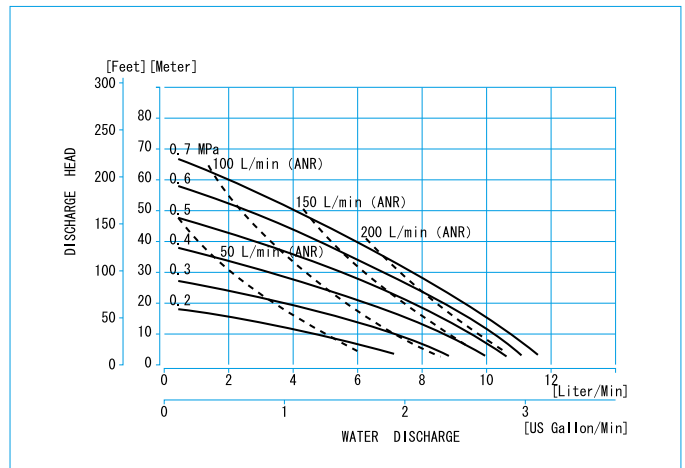

DP-10 SERIES / DP-15 SERIES

Maximum Capacity 20 l/min
Port Size 3/8" (10 mm)

Maximum Capacity 27 l/min
Port Size 1/2" (15 mm)



DP-10 Aluminum

Dimensions:
186 mm W x 241 mm H
Net Wt.: 3,5 kg
Maximum Capacity: 20 l/min

DP-10 Polypropylene

Dimensions:
195 mm W x 196 mm H
Net Wt.: 3,0 kg
Maximum Capacity: 17 l/min



DP-15 Polypropylene

Dimensions:
246 mm W x 297 mm H
Net Wt.: 3,5 kg
Maximum Capacity: 27 l/min



DP-10 Stainless Steel

Dimensions:
186 mm W x 237 mm H
Net Wt.: 5,2 kg
Maximum Capacity: 20 l/min



DP-10 / DP-15 SERIES SPECIFICATIONS

DP-10 Port Dimensions

Intake & discharge connection:

Polypropylene (PPG)	3/8" 10 mm Female Rc
Aluminum (ADC-12)	3/8" 10 mm Female Rc
Stainless Steel (SCS14)	3/8" 10 mm Female Rc

DP-15 Port Dimensions

Intake & discharge connection:

Polypropylene (PPG)	1/2" 15 mm Female Rc
---------------------	----------------------

Air Inlet/Exhaust

Air inlet (incl. ball valve):	1/4" 6 mm Female Rc
Air exhaust (incl. silencer):	3/8" 10 mm Female Rc

Air Supply Pressure (All Models)

2,0 – 7,0 Bar (0,2 – 0,7 MPa)

Discharge Volume Per Cycle

DP-10: 50 mL

DP-15: 55 mL

Maximum Size Solid

1,0 mm Ball Valve / 0,0 mm Flat Valve

Maximum Suction Lift

All diaphragms: 1 m

Air Motors

Standard: Aluminum

Optional: Teflon®-coated

Notes:

Hytrel®-fitted pumps include Buna-N wetted o-rings.

Santoprene®-fitted pumps include EPDM wetted o-rings.

DP-10 Series Performance Curve

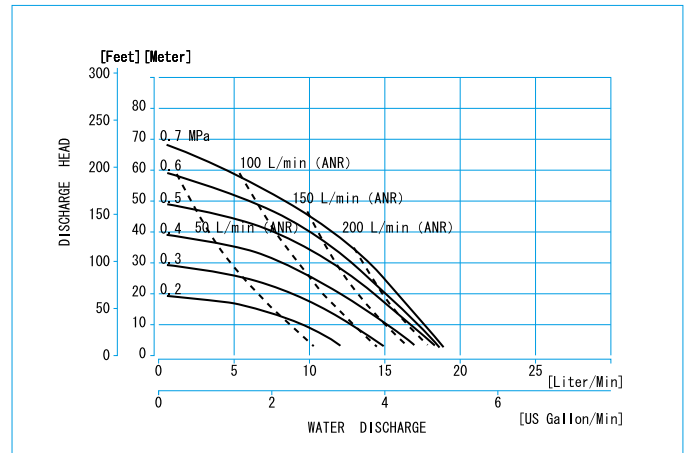

DP-15 Series Performance Curve

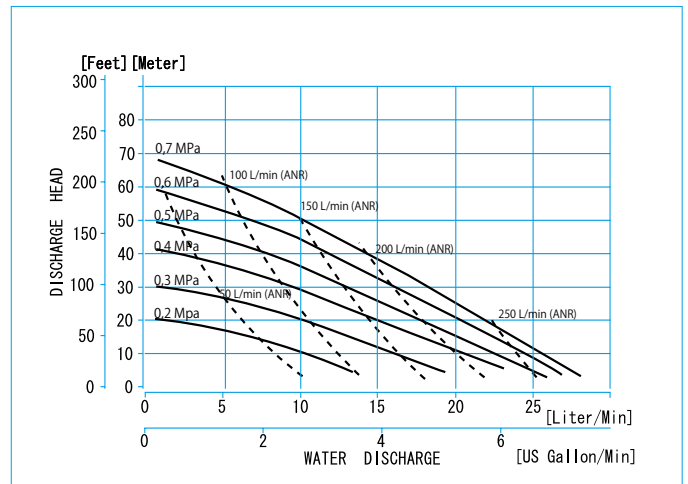

Model Number Nomenclature

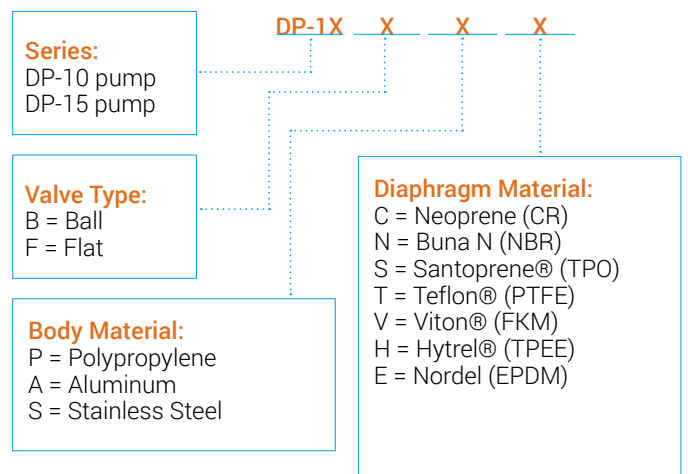

DP-15 standard with flat valves.

Ball valve is optional.

Additional options listed on page 43.

NDP-15 SERIES

Maximum Capacity 50 l/min
Port Size 1/2" (15 mm)



NDP-15 Polypropylene
Dimensions:
220 mm W x 297 mm H
Net Wt.: 3,5 kg
Maximum Capacity: 45 l/min

NDP-15 Conductive Kynar®
Dimensions:
220 mm W x 297 mm H
Net Wt.: 4,3 kg
Maximum Capacity: 45 l/min



NDP-15 Aluminum
Dimensions:
220 mm W x 269 mm H
Net Wt.: 4,1 kg
Maximum Capacity: 50 l/min



NDP-15 Stainless Steel
Dimensions:
211 mm W x 247 mm H
Net Wt.: 6,3 kg
Maximum Capacity: 50 l/min



NDP-15 SERIES SPECIFICATIONS

Port Dimensions

Intake & discharge connection:

Polypropylene (PPG)	1/2" 15 mm Female Rc
Conductive Kynar® (PVDF)	1/2" 15 mm Female Rc
Aluminum (ADC-12)	1/2" 15 mm Female Rc
Stainless Steel (SCS14)	1/2" 15 mm Female Rc

Air Inlet/Exhaust

Air inlet (incl. ball valve):	1/4" 6 mm Female Rc
Air exhaust (internal silencer):	3/8" 10 mm Female Rc

Air Supply Pressure (All Models)

2,0 – 7,0 Bar (0,2 – 0,7 MPa)

Discharge Volume Per Cycle

70 mL

Maximum Size Solid

1,0 mm Ball Valve / Flat Valve 0,0 mm

Maximum Suction Lift

Flat-type check valve: 2,4 m

Ball-type check valve: 1 m

Air Motor

Standard: Ryton® air motor

Notes:

Hytre®-fitted pumps include Buna-N wetted o-rings.

Santoprene®-fitted pumps include EPDM wetted o-rings.

Kynar® (PVDF) pumps fitted with Santoprene®, Hytre®, or

Teflon® include Teflon® o-rings.

Flat valves are standard PTFE.

Model Number Nomenclature

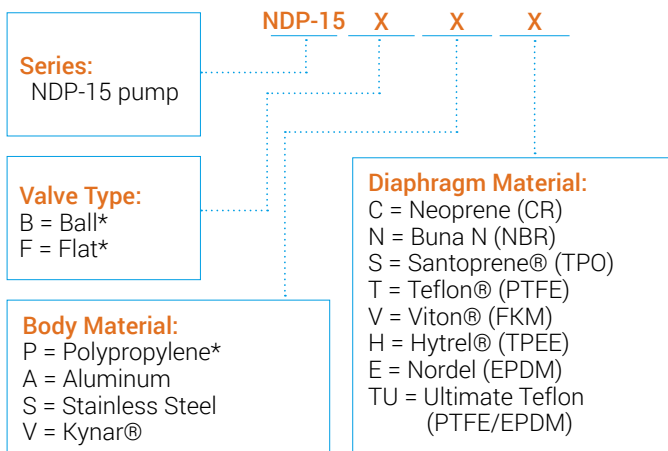

Metal Pump Performance Curve

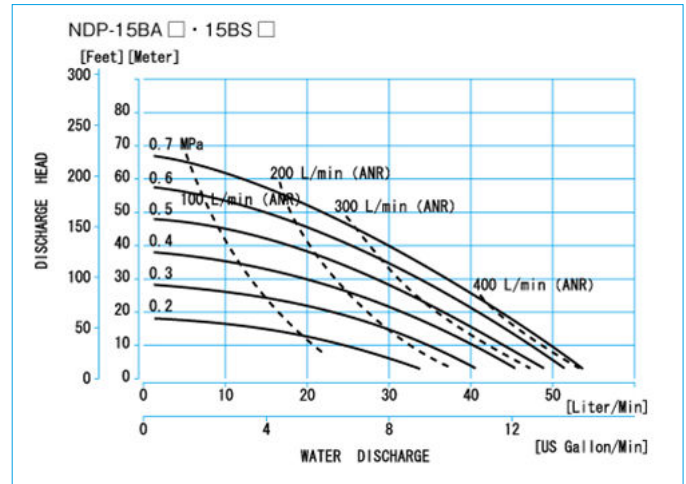

Plastic Pump Performance Curve

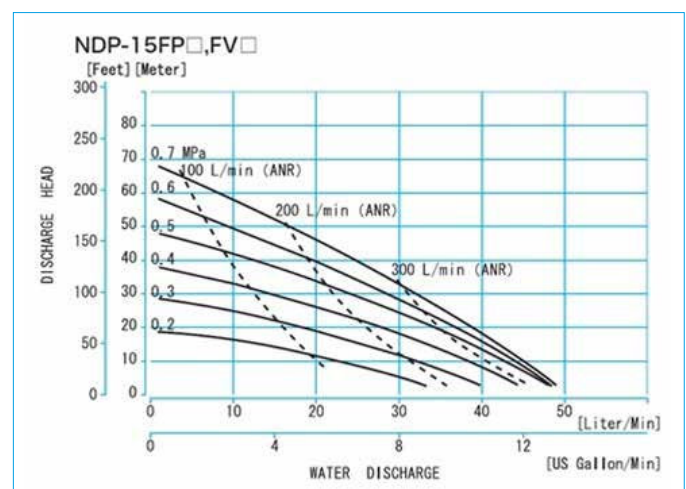
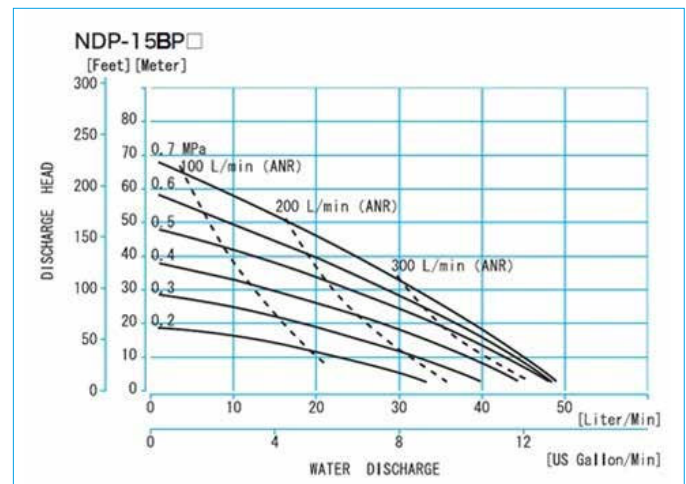

* Flat valves standard for NDP-15 Plastic pumps
 * Ball valves optional for PPG pumps NDP-15 only
 Additional options listed on page 43.

NDP-20 SERIES

Maximum Capacity 110 l/min
Port Size 3/4" (20 mm)



NDP-20 Aluminum

Dimensions:
249 mm W x 317 mm H
Net Wt.: 9,0 kg
Maximum Capacity: 110 l/min
*PTFE diaphragm 100 l/min

NDP-P20 Polypropylene-Rc

Dimensions:
317 mm W x 368 mm H
Net Wt.: 7,0 kg
Maximum Capacity: 110 l/min
*PTFE diaphragm 100 l/min



NDP-P20 Polypropylene-DN Flange

Dimensions:
316 mm W x 374 mm H
Net Wt.: 7,0 kg
Maximum Capacity: 110 l/min
*PTFE diaphragm 100 l/min



NDP-20 Stainless Steel

Dimensions:
245 mm W x 315 mm H
Net Wt.: 14,0 kg
Maximum Capacity: 110 l/min
*PTFE diaphragm 100 l/min



NDP-20 SERIES SPECIFICATIONS

Port Dimensions

Intake & discharge connection:

Polypropylene (PPG)	3/4" 20 mm Female Rc
Aluminum (ADC-12)	3/4" 20 mm Female Rc
Stainless Steel (SCS14)	3/4" 20 mm Female Rc
Air inlet (incl. ball valve):	1/4" 6 mm Female Rc
Air exhaust (incl. silencer):	3/4" 20 mm Female Rc

DN & ANSI Flange also available—consult Yamada.

Notes: Flange connections are equivalent to DN 20 PN 10 and JIS 10K 20A and ANSI 150 3/4 B

Air Supply Pressure (All Models)

2,0 – 7,0 Bar (0,2 – 0,7 MPa)

Discharge Volume Per Cycle

Rubber diaphragm: 350 mL

PTFE diaphragm: 240 mL

Maximum Size Solid

2,0 mm or less

Maximum Suction Lift

Rubber-fitted pump capability: 3 m

PTFE-fitted pump capability: 1,5 m

Air Motors

Metal pumps standard with aluminum motor.

Options for aluminum motor: Teflon®-coated protection

Plastic pumps standard with PPG motor.

PPG motor also optional for metal pumps.

Notes:

Hytrel®-fitted pumps include Buna-N wetted o-rings.

Santoprene®-fitted pumps include EPDM wetted o-rings.

Model Number Nomenclature

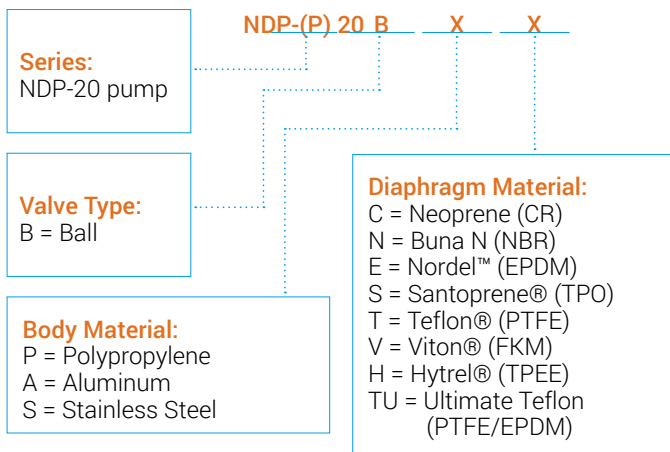

Metal Pump Performance Curve

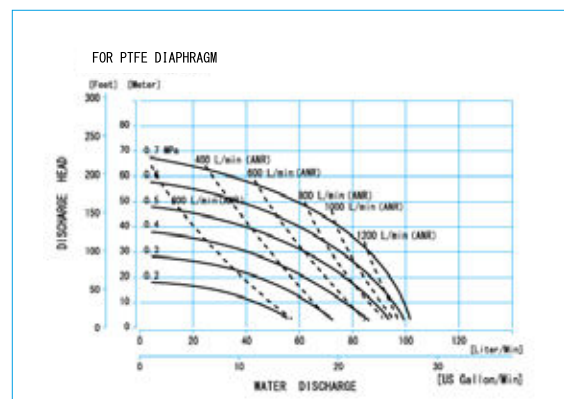
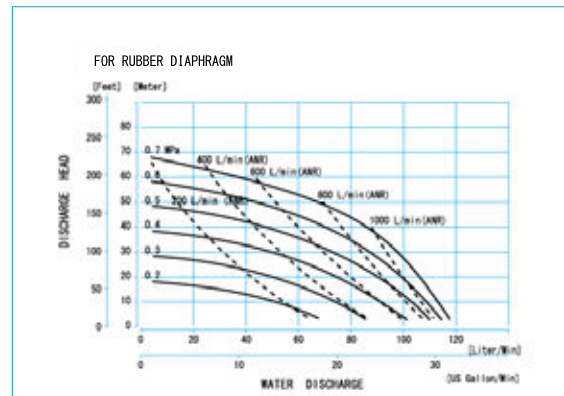

Plastic Pump Performance Curve

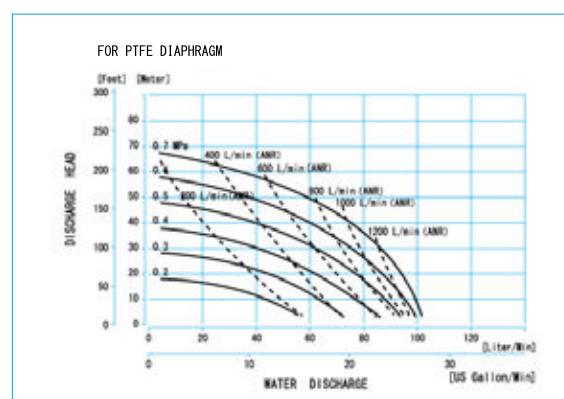
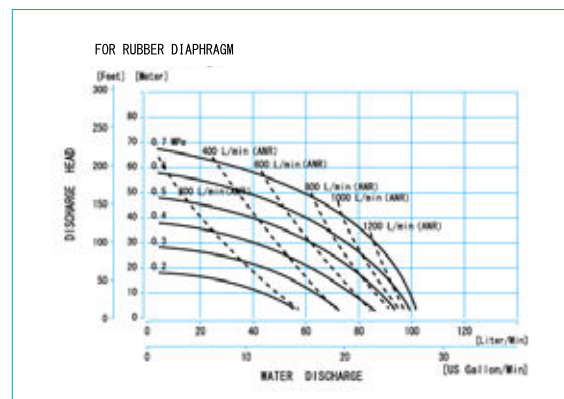

Additional options listed on page 43.

NDP-25 SERIES

Maximum Capacity 160 l/min
Port Size 1" (25 mm)



NDP-P25 Polypropylene -DN Flange
Dimensions: 367 mm W x 422 mm H
Net Wt.: 9,5 kg
Maximum Capacity: 160 l/min

NDP-P25 Polypropylene -Rc
Dimensions:
368 mm W x 429 mm H
Net Wt.: 9,5 kg
Maximum Capacity: 160 l/min



NDP-25 Conductive Kynar®-Rc
Dimensions:
367 mm W x 429 mm H
Net Wt.: 13,5 kg
Maximum Capacity: 160 l/min



NDP-P25 Kynar®-DN Flange
Dimensions:
367 mm W x 442 mm H
Net Wt.: 12,0 kg
Maximum Capacity: 160 l/min



NDP-25 Aluminum
Dimensions: 287 mm W x 379 mm H
Net Wt.: 13,0 kg
Maximum Capacity: 160 l/min

NDP-25 Stainless Steel
Dimensions: 287 mm W x 375 mm H
Net Wt.: 20,0 kg
Maximum Capacity: 160 l/min

NDP-25 Cast Iron
Dimensions: 284 mm W x 375 mm H
Net Wt.: 20,0 kg
Maximum Capacity: 160 l/min



NDP-25 SERIES SPECIFICATIONS

Port Dimensions

Intake & discharge connection:

Polypropylene (PPG)	1" 25 mm Female Rc
Conductive Kynar® (PVDF)	1" 25 mm Female Rc
Aluminum (ADC-12)	1" 25 mm Female Rc
Stainless Steel (SCS14)	1" 25 mm Female Rc
Cast Iron	1" 25 mm Female Rc
Air inlet (incl. ball valve):	3/8" 10 mm Female Rc
Air exhaust (incl. silencer):	3/4" 20 mm Female Rc

DN & ANSI Flange also available—consult Yamada.

Notes: Flange connections are equivalent to DN 25 PN 10 and JIS 10K 25A

Air Supply Pressure (All Models)

2,0 – 7,0 Bar (0,2 – 0,7 MPa)

Discharge Volume Per Cycle

Rubber diaphragm: 600 mL

PTFE diaphragm: 500 mL

Maximum Size Solid

3,0 mm or less

Maximum Suction Lift

Rubber-fitted pump capability: 5,0 m

PTFE-fitted pump capability: 2,0 m

Air Motors:

Metal pumps standard with aluminum motor.

Options for aluminum motor: Teflon®-coated protection.

Plastic pumps standard with PPG motor.

PPG motor also optional for metal pumps.

Anodic coated aluminum motor for ATEX conform PVDF pump.

Notes:

Hytrel®-fitted pumps include Buna-N wetted o-rings.

Santoprene®-fitted pumps include EPDM wetted o-rings.

Kynar® (PVDF) pumps:

fitted with Santoprene® : santoprene balls and PTFE o-rings.

fitted with Hytrel®: hytrell balls and PTFE o-rings.

Model Number Nomenclature

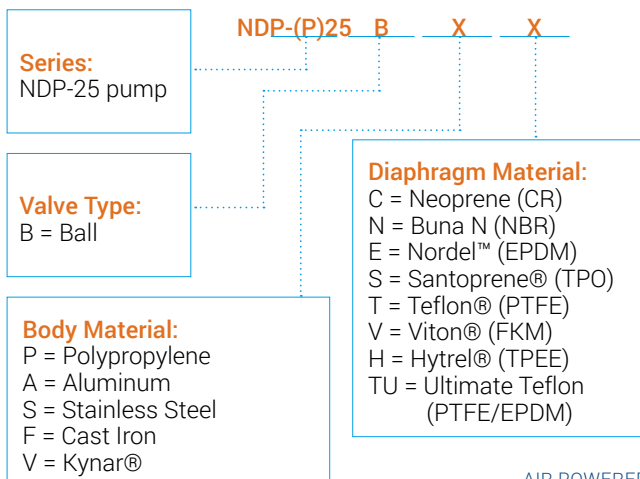

Metal Pump Performance Curve

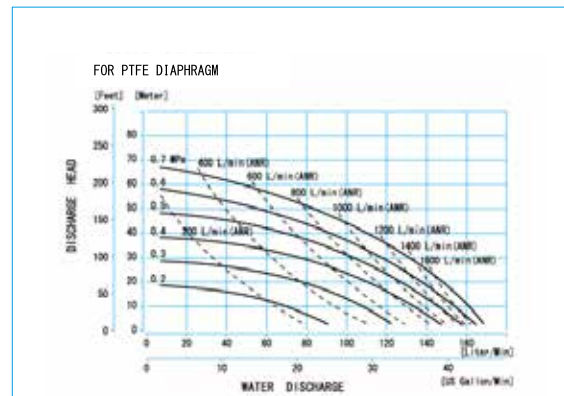
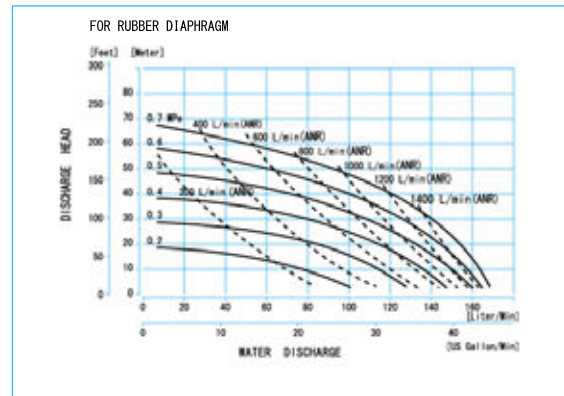

Plastic Pump Performance Curve

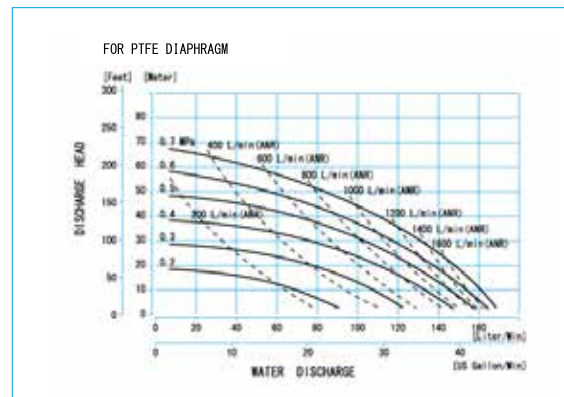
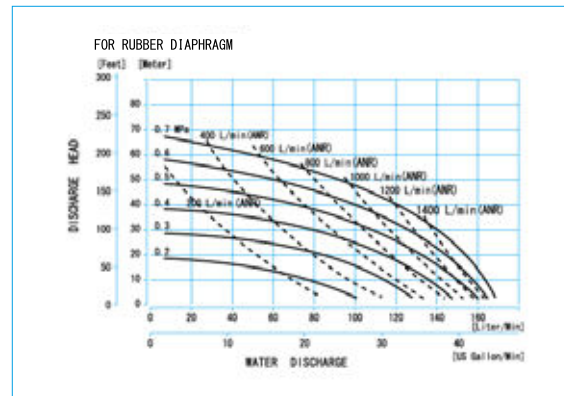

Additional options listed on page 43.

NDP-40 SERIES

Maximum Capacity 400 l/min
Port Size 1-1/2" (40 mm)



NDP-40 Polypropylene

Dimensions:

402 mm W x 752 mm H

Net Wt.: 27,0 kg

Maximum Capacity: 370 l/min

*PTFE diaphragm 330 l/min



NDP-40 Aluminum

Dimensions:

412 mm W x 710 mm H

Net Wt.: 27,0 kg

Maximum Capacity: 400 l/min

*PTFE diaphragm 350 l/min



NDP-40 Stainless Steel

Dimensions:

411 mm W x 705 mm H

Net Wt.: 42,8 kg

Maximum Capacity: 400 l/min

*PTFE diaphragm 350 l/min



NDP-40 Conductive Kynar® (PVDF)

Dimensions:

402 mm W x 751 mm H

Net Wt.: 32,0 kg

Maximum Capacity: 370 l/min

*PTFE diaphragm 330 l/min

NDP-40 Cast Iron

Dimensions:

411 mm W x 704 mm H

Net Wt.: 47,2 kg

Maximum Capacity: 400 l/min

*PTFE diaphragm 350 l/min

ANSI 150 FLANGE AVAILABLE ON POLYPROPYLENE,
ALUMINUM, STAINLESS STEEL AND KYNAR PUMPS.

NDP-40 SERIES SPECIFICATIONS

Port Dimensions

Intake & discharge connection:

Polypropylene (PPG)	1-1/2" 40 mm DN40 PN10
Conductive Kynar® (PVDF)	1-1/2" 40 mm DN40 PN10
Aluminum(ADC-12)	1-1/2" 40 mm DN40 PN10 (Combi Flange with tapped 1-1/2" 40 mm Female Rc)
Stainless Steel (SCS14)	1-1/2" 40 mm DN40 PN10
Cast Iron	1-1/2" 40 mm Female Rc
Air inlet (incl. ball valve):	1/2" 15 mm Female Rc
Air exhaust (incl. silencer):	1" 25 mm Female Rc

Notes: Flange connections are equivalent to DN 40 PN 10 and JIS 10K 40A

Air Supply Pressure (All Models)

2,0 – 7,0 Bar (0,2 – 0,7 MPa)

Discharge Volume Per Cycle

Rubber diaphragm: 2800 mL

PTFE diaphragm: 1400 mL

TU diaphragm: 1300 mL

TU diaphragm + PVDF or PPG body: 1400 mL

Maximum Size Solid

7,0 mm or less

Maximum Suction Lift

Rubber-fitted pump capability: 5,0 m

PTFE-fitted pump capability: 3,0 m

Air Motor

Standard: Aluminum

Optional: Teflon®-coated

Notes:

Hytrel®-fitted pumps include Buna-N wetted o-rings.

Santoprene®-fitted pumps include EPDM wetted o-rings.

Kynar® (PVDF) pumps:

fitted with Santoprene® : santoprene balls and PTFE o-rings.

fitted with Hytrel®: hytre balls and PTFE o-rings.

Model Number Nomenclature

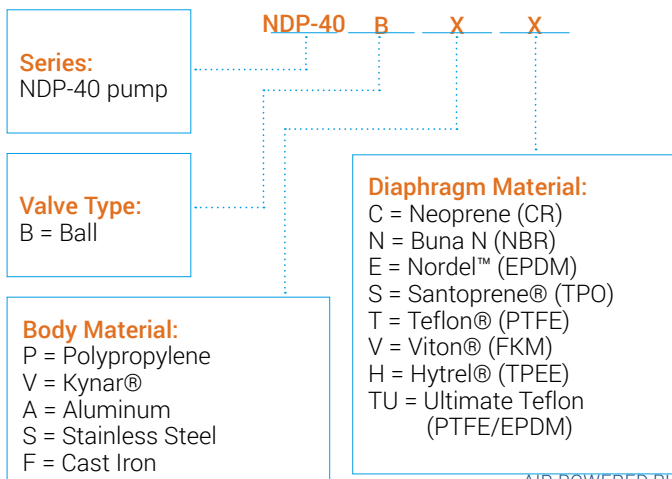

Metal pump Performance Curve

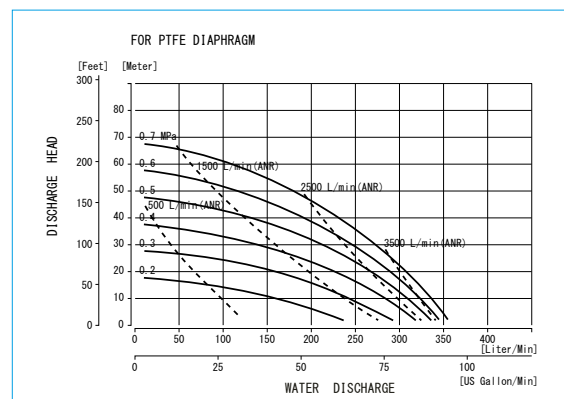
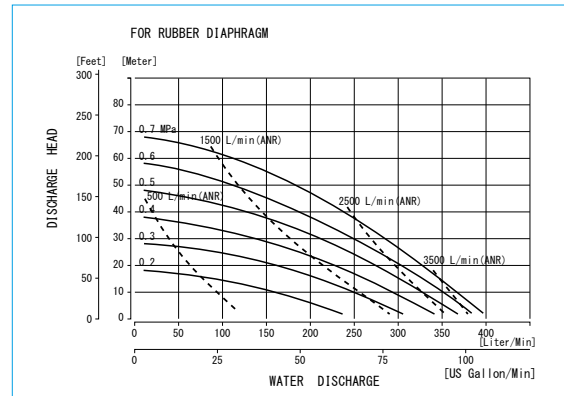

Plastic Pump Performance Curve

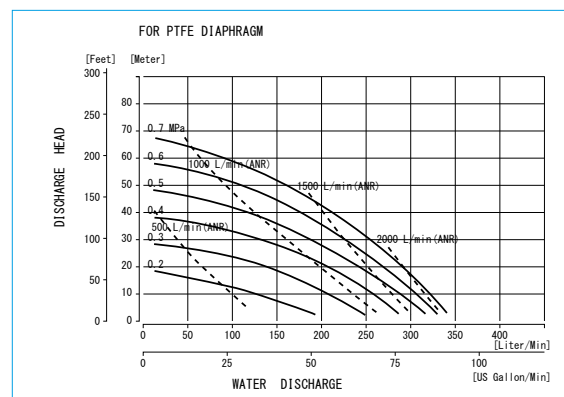
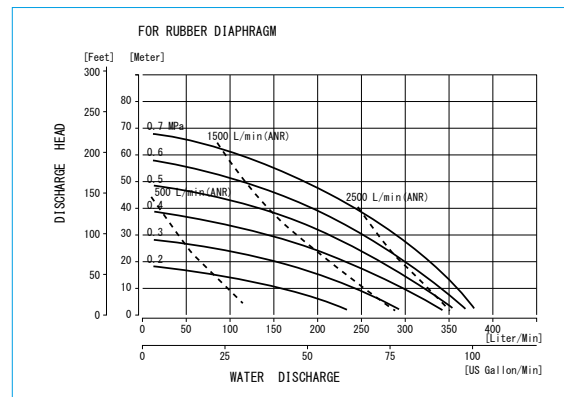

Additional options listed on page 43.

NDP-50 SERIES

Maximum Capacity 630 l/min
Port Size 2" (50 mm)



NDP-50 Cast-iron

Dimensions: 450 mm W x 776 mm H
Net Wt.: 65,0 kg
Maximum Capacity: 630 l/min
*PTFE diaphragm 600 l/min

NDP-50 Aluminum
Dimensions:
452 mm W x 780 mm H
Net Wt.: 34,5 kg
Maximum Capacity: 630 l/min
*PTFE diaphragm 600 l/min

NDP-50 Stainless Steel
Dimensions:
450 mm W x 782 mm H
Net Wt.: 62,0 kg
Maximum Capacity: 630 l/min
*PTFE diaphragm 600 l/min

NDP-P50 Polypropylene
Dimensions:
465 mm W x 821 mm H
Net Wt.: 37,0 kg
Maximum Capacity: 630 l/min
*PTFE diaphragm 560 l/min
*TU diaphragm 580 l/min

**NDP-50 Conductive
Kynar® (PVDF)**
Dimensions:
462 mm W x 819 mm H
Net Wt.: 41,0 kg
Maximum Capacity: 600 l/min
*PTFE diaphragm 550 l/min



NDP-50 SERIES SPECIFICATIONS

Port Dimensions

Intake & discharge connection:

Polypropylene (PPG)	2" 50 mm DN50 PN10
Conductive Kynar® (PVDF)	2" 50 mm DN50 PN10
Aluminum (ADC-12)	2" 50 mm DN50 PN10 (Combi Flange with tapped 2" 50 mm Female Rc)
Stainless Steel (SCS14)	2" 50 mm DN50 PN10
Cast Iron	2" 50 mm Female Rc
Air inlet (incl. ball valve):	3/4" 20 mm Female Rc
Air exhaust (incl. silencer):	1" 25 mm Female Rc

Notes: Flange connections are equivalent to DN 50 PN 10 and JIS 10K 50A and ANSI 150 2

Air Supply Pressure (All Models)

2,0 – 7,0 Bar (0,2 – 0,7 MPa)

Discharge Volume Per Cycle

	P50
Rubber diaphragm: 4300 mL	4100 mL
PTFE diaphragm: 2100 mL	2300 mL
TU diaphragm: 2600 mL	1600 mL

TU diaphragm + PVDF body: 2000 mL

Maximum Size Solid

8,0 mm or less

Maximum Suction Lift

Rubber-fitted pump capability: 5,0 m

PTFE-fitted pump capability: 3,0 m

Air Motor

Standard: PPG for Polypropylene pumps

Standard: Aluminum for all others.

Optional: Teflon®-coated

Optional for all pumps standard fitted with aluminum motor is the PPG motor.

Notes:

Hytrell®-fitted pumps Buna-N wetted o-rings.

Santoprene®-fitted pumps EPDM wetted o-rings.

Kynar® (PVDF) pumps:

fitted with Santoprene® santoprene balls and PTFE o-rings.

fitted with Hytrell® : hytrell balls and PTFE o-rings.

Model Number Nomenclature

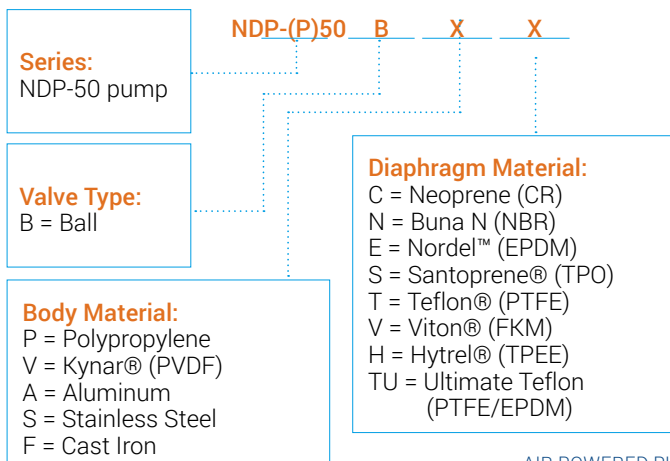

Metal pump Performance Curve

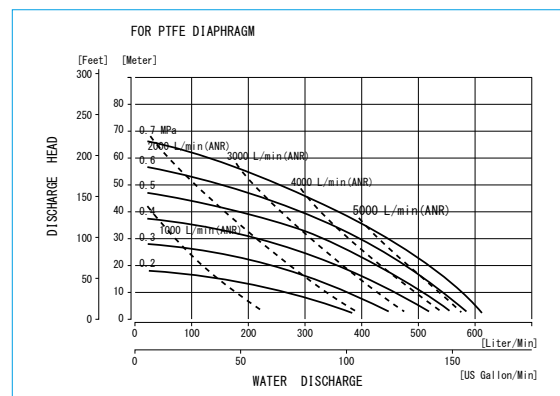
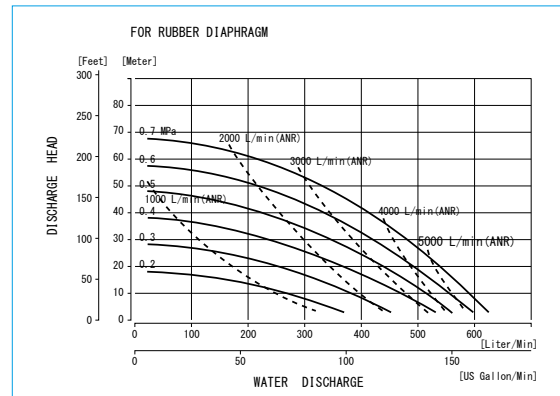

Plastic Pump Performance Curve

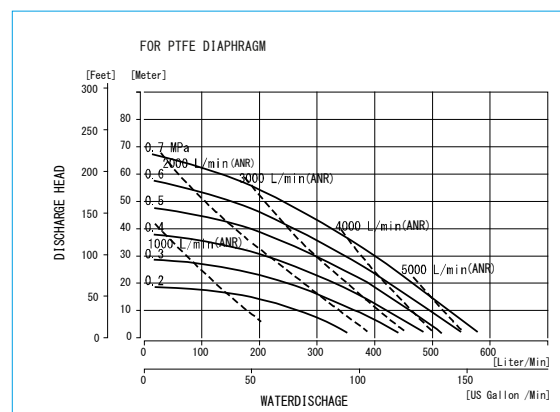
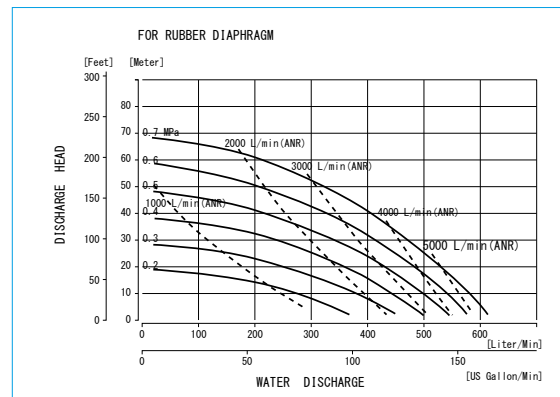

Additional options listed on page 43.

NDP-80 SERIES

Maximum Capacity 840 l/min
Port Size 3" (80 mm)



NDP-80 Stainless Steel

Dimensions: 521 mm W x 984 mm H
Net Wt.: 109,0 kg
Maximum Capacity: 840 l/min
*PTFE diaphragm 640 l/min

NDP-80 Aluminum

Dimensions:
522 mm W x 998 mm H
Net Wt.: 62,0 kg
Maximum Capacity: 840 l/min
*PTFE diaphragm 640 l/min



NDP-80 Cast Iron

Dimensions:
521 mm W x 984 mm H
Net Wt.: 109,5 kg
Maximum Capacity: 840 l/min
*PTFE diaphragm 640 l/min



NDP-80 Polypropylene

Dimensions:
580 mm W x 1044 mm H
Net Wt.: 65,5kg
Maximum Capacity: 800 l/min
*PTFE diaphragm 580 l/min



NDP-80 SERIES SPECIFICATIONS

Port Dimensions

Intake & discharge connection:

Polypropylene (PPG)	3" 80 mm DN 80 PN 10
Aluminum (ADC-12)	3" 80 mm DN 80 PN 10 (Combi Flange with tapped 3" 80 mm Female Rc)
Stainless Steel (SCS14)	3" 80 mm DN 80 PN 10
Cast Iron	3" 80 mm Female Rc
Air inlet (incl. ball valve):	3/4" 20 mm Female Rc
Air exhaust (incl. silencer):	1" 25 mm Female Rc

Notes: Flange connections are equivalent to DN 80 PN 10 and JIS 10K 80A and ANSI 150 3

Air Supply Pressure (All Models)

2,0 – 7,0 Bar (0,2 – 0,7 MPa)

Discharge Volume Per Cycle

Rubber diaphragm: 8500 mL

PTFE diaphragm: 3800 mL

TU diaphragm: 5200 mL

TU diaphragm + PPG body: 5000 mL

Maximum Size Solid

10,0 mm or less

Maximum Suction Lift

Rubber-fitted pump capability: 5,0 m

PTFE-fitted pump capability: 3,0 m

Air Motor

Standard: Aluminum

Optional: Teflon®-coated

Notes:

Hytrel®-fitted pumps include Buna-N wetted o-rings.

Santoprene®-fitted pumps EPDM wetted o-rings.

Kynar® (PVDF) pumps:

fitted with Santoprene®: santoprene balls and PTFE o-rings.

fitted with Hytrel®: hytrel balls and PTFE o-rings.

Model Number Nomenclature

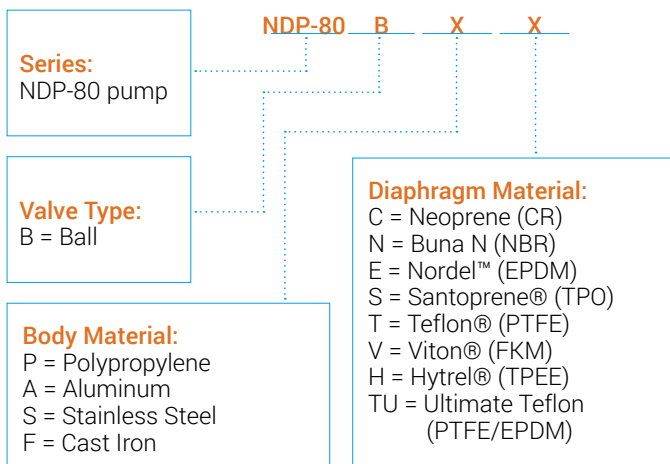

Metal Pump Performance Curve

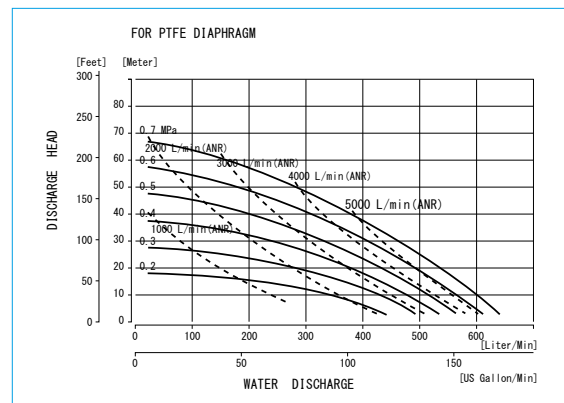
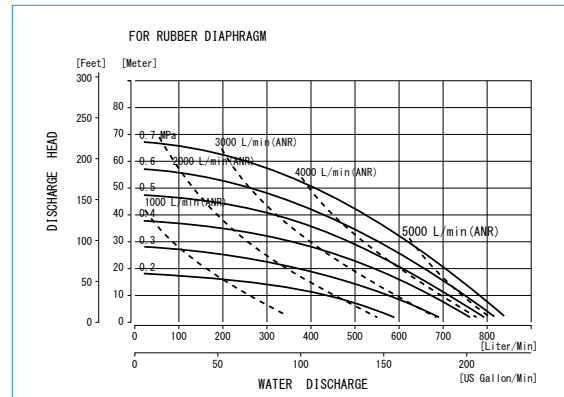

Plastic Pump Performance Curve

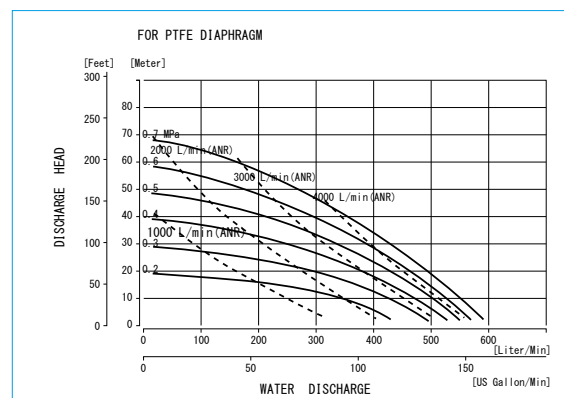
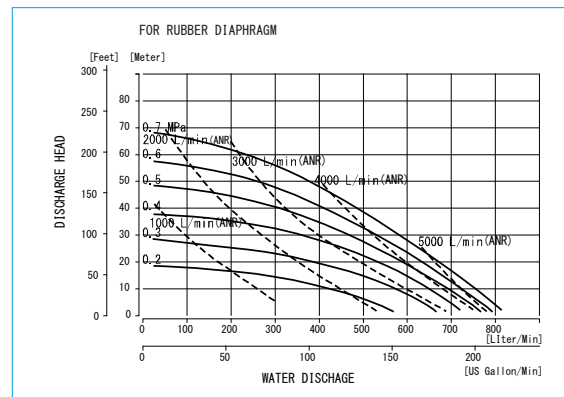

Additional options listed on page 43.

DIMENSIONAL DRAWINGS

NDP-5, DP-10, NDP-15, NDP-20
and NDP-25 Series

NDP-5FAT-FST

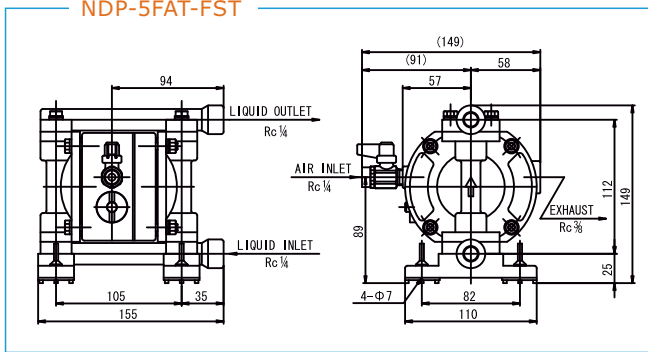

NDP-5FPT-FVT-FDT

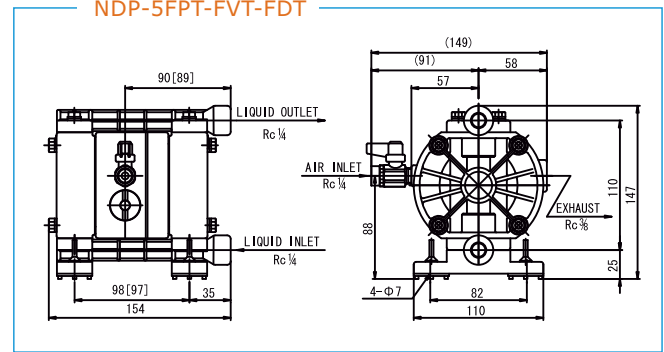

DP-10BA-BS

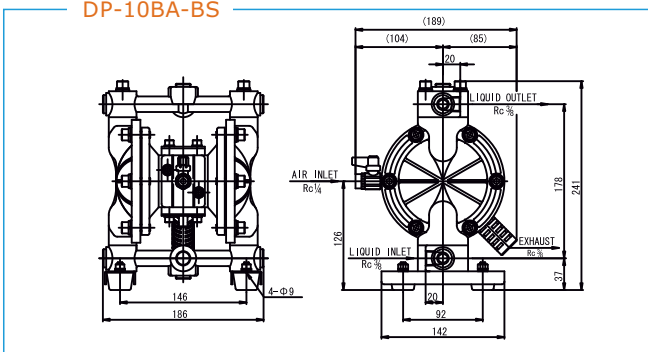

DP-10BP

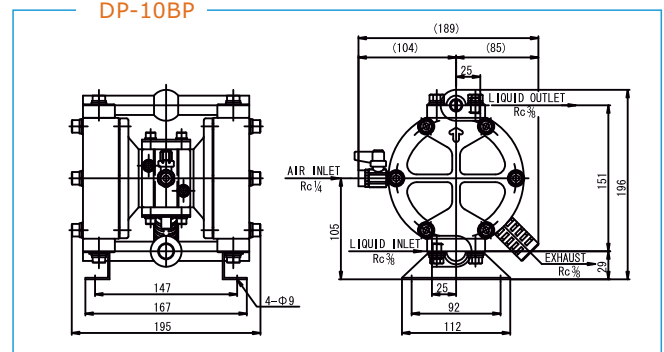

NDP-15BA

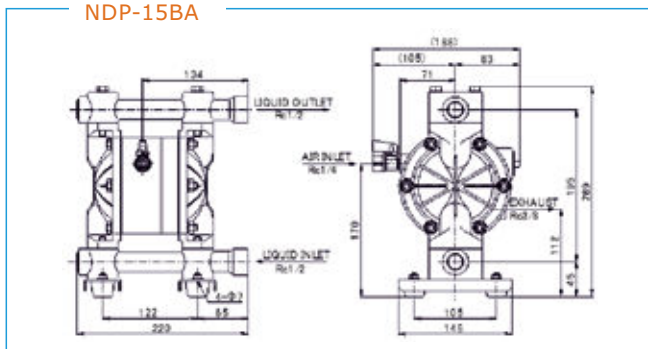

NDP-15BS

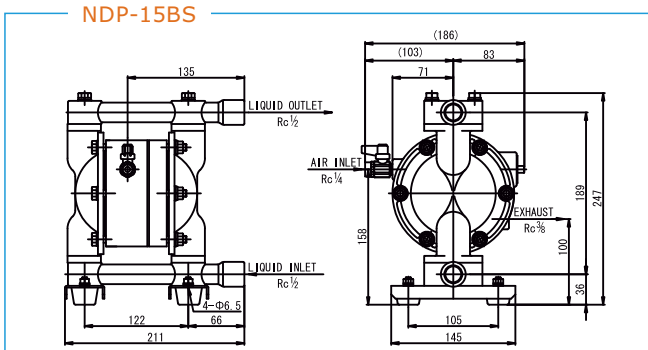

NDP-15BP-FP-FV

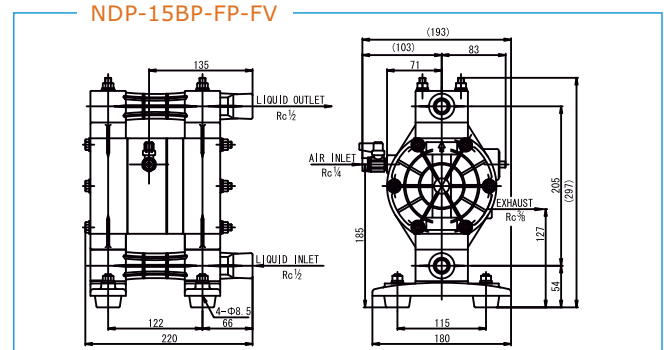

NDP-20BA

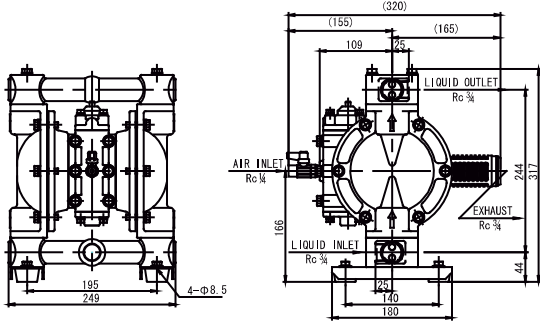

NDP-20BS

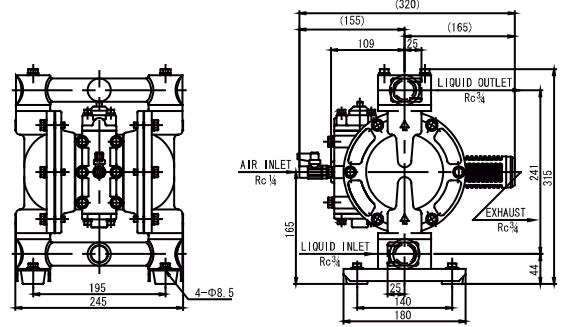

NDP-P20BP

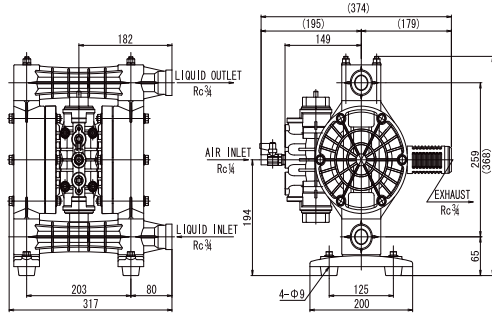

NDP-P20BP-FL

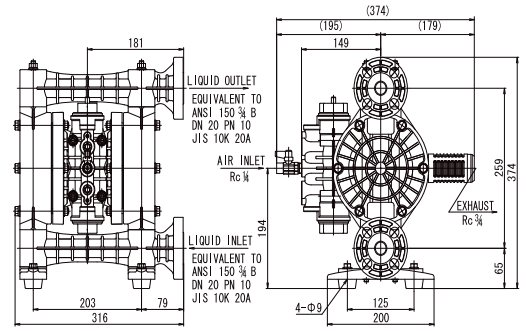

NDP-25BA

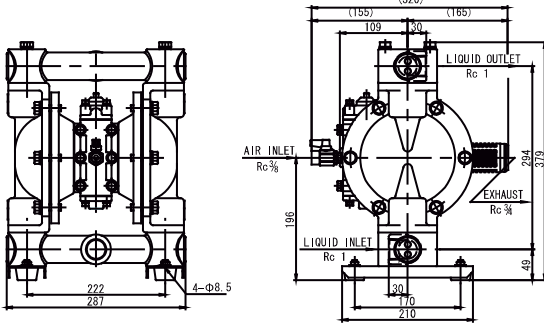

NDP-25BF

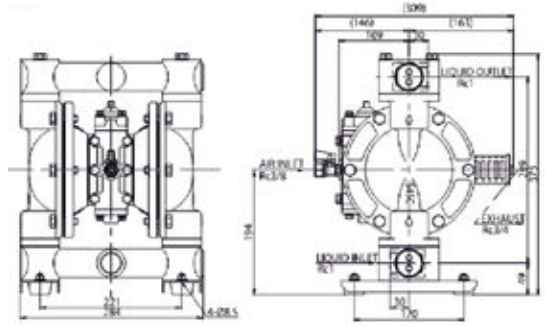

NDP-25BS

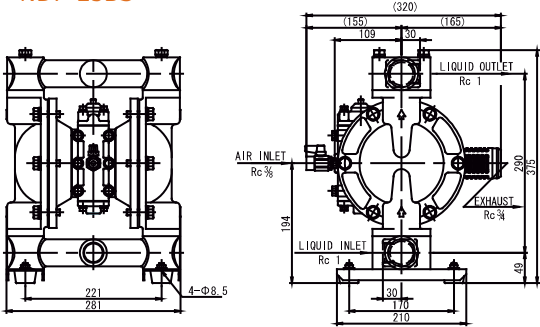

NDP-P25BP

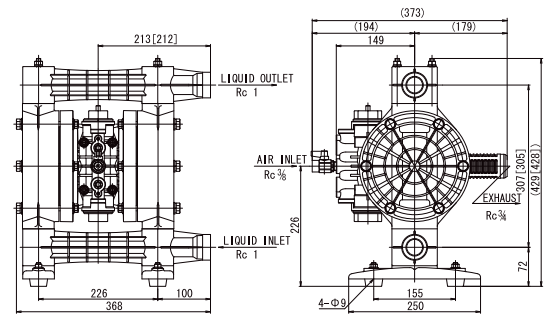

NDP-P25BP-FL

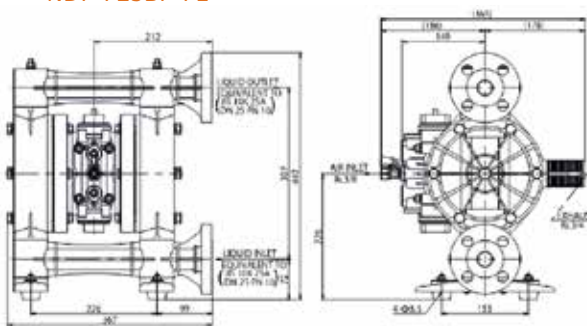

NDP-P25BV

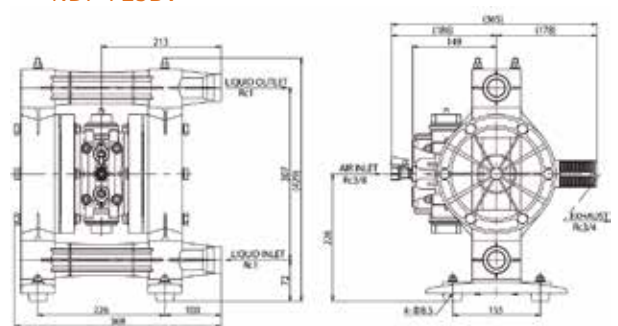

DIMENSIONAL DRAWINGS

NDP-25, NDP-32, NDP-40, NDP-50
and NDP-80 Series

NDP-P25BV-FL

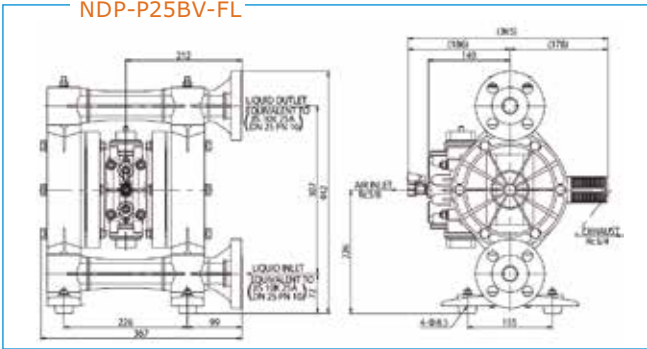

NDP-25BV

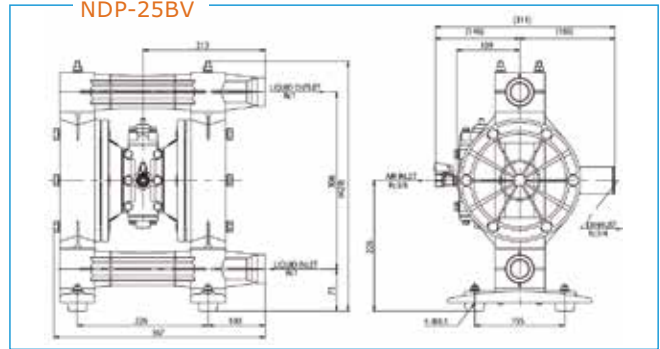

NDP-25BV-FL

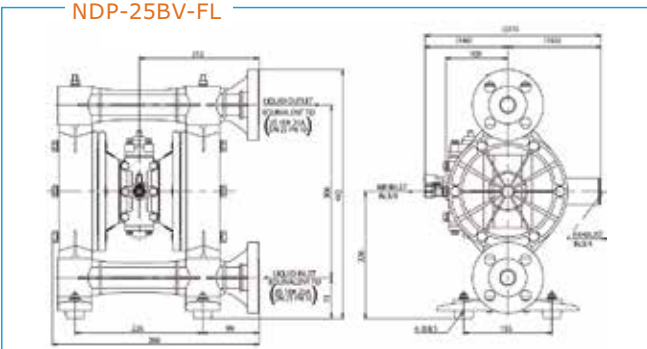

NDP-32BA

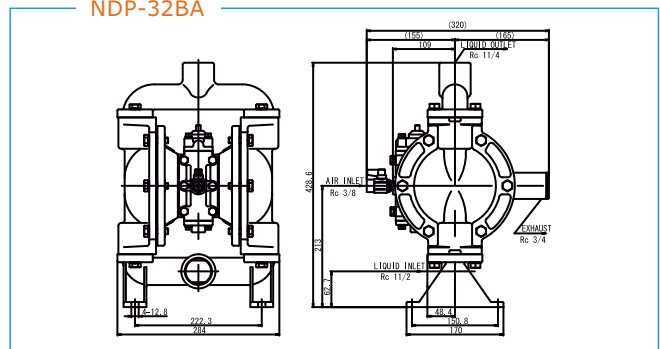

NDP-40BA

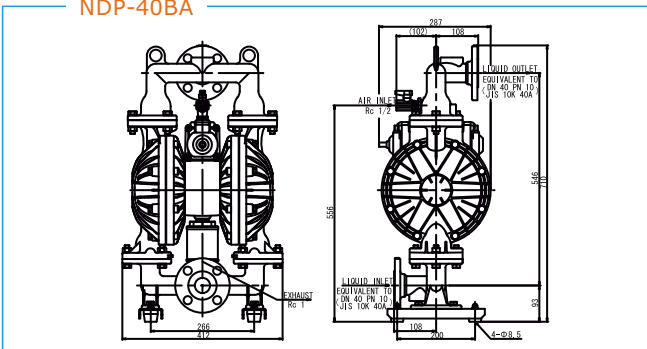

NDP-40BF

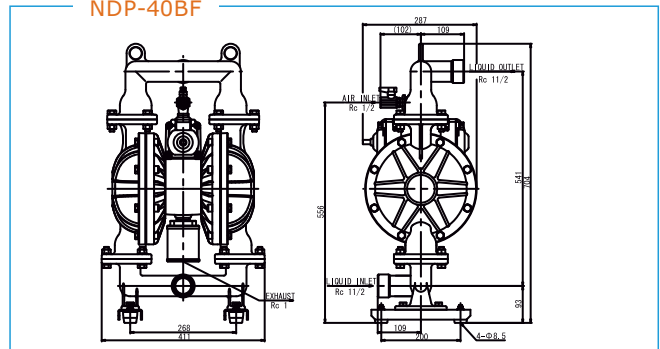

NDP-40BS

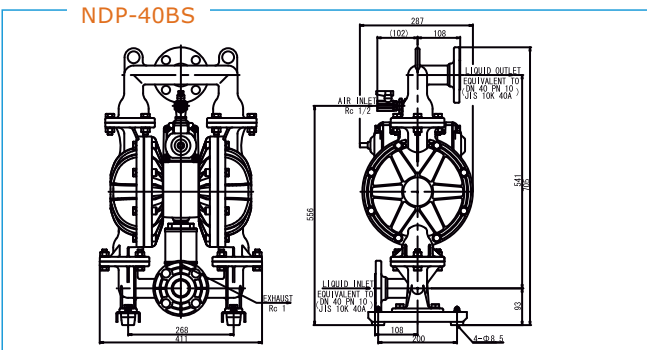

NDP-40BP

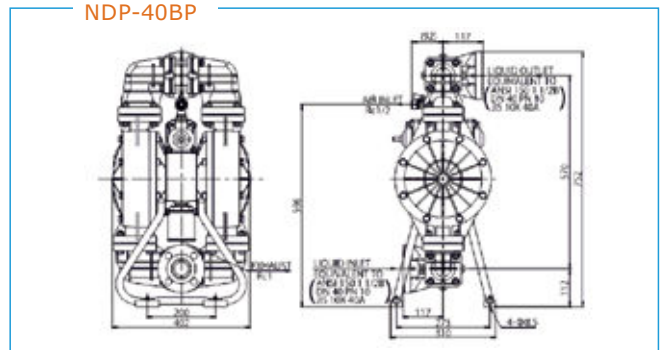

NDP-40BV

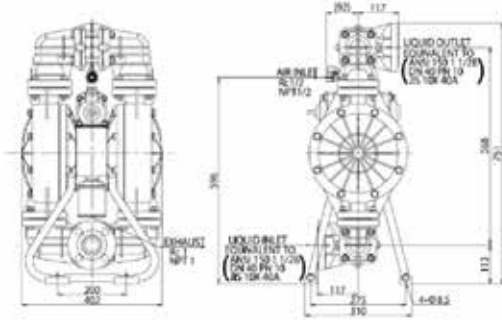

NDP-50BA

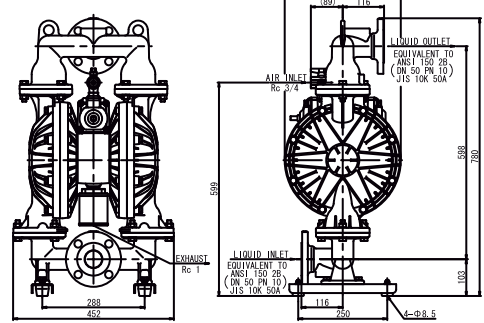

NDP-50BF

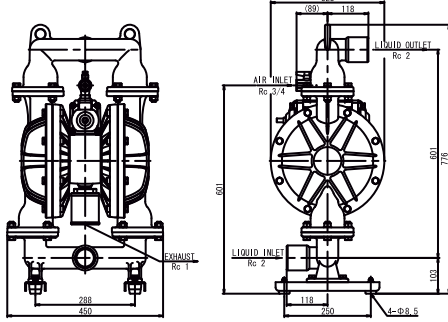

NDP-50BS

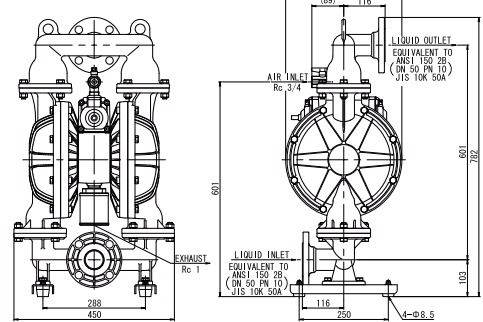

NDP-P50BP

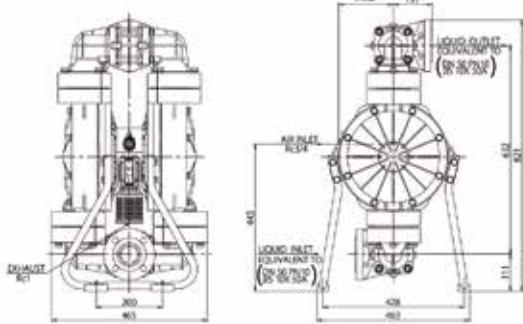

NDP-50BV

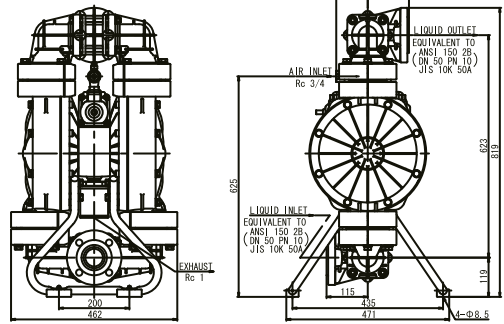

NDP-80BA

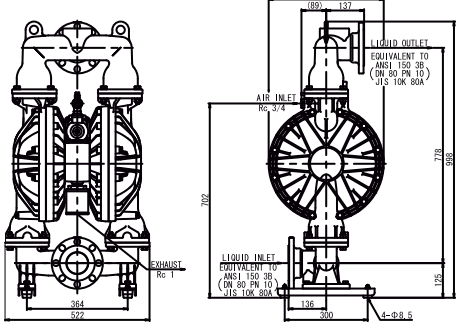

NDP-80BF

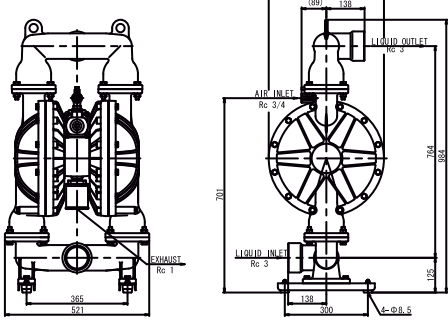

NDP-80BS

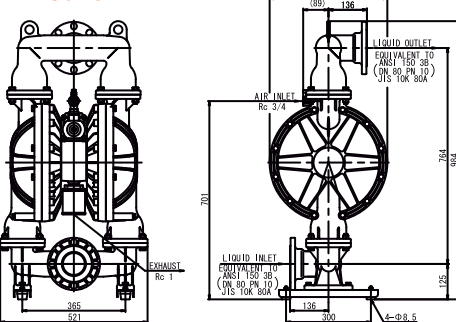

NDP-80BP

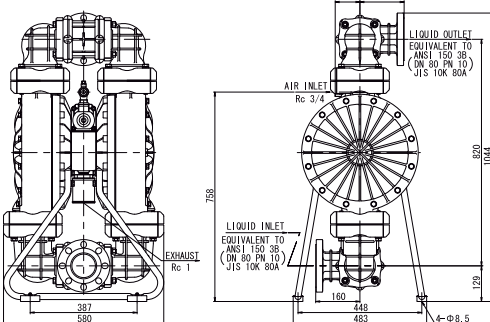

GLOBAL SERIES

GLOBAL SERIES
Air-Operated Double Diaphragm Pumps



G15 Aluminum



G15 Polypropylene



G15 Stainless Steel



G15 Kynar



G25 Aluminum



Step Spool

G15 / G25 GLOBAL SERIES

G15 Global Series 1/2" AODD pumps provide a maximum flow rate of 62 l/min and are available in Aluminum, Stainless Steel, Pure Polypropylene and Kynar.

G25 Global Series 1" AODD pumps provide a maximum flow rate of 150 l/min and are available in Aluminum.

We also offer a wide selection of diaphragm materials.

The various combinations of pump housing and diaphragm materials allow to cover a wide range of applications.

Yamada Global Series pumps do not have an independent pilot valve system (less parts) and consume less air versus the competition.

The new G-series pumps utilize our new step spool (S-Spool), which provides stall-free operation.

Available with multiport options, these AODD pumps perform extremely well in continuous stop/start operations (dead-head applications) and provide exceptional suction lift.

The G-series pumps have fewer removable parts, which makes the maintenance and repair quick, easy and cost-effective.

Soon coming:

G25 stainless steel and polypropylene

G50 aluminum

Stall-Free Operation

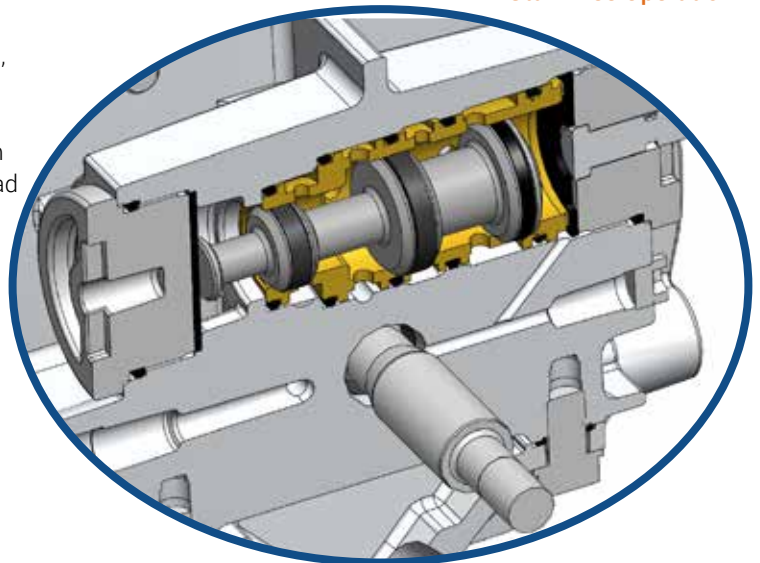

Dimensional Drawings

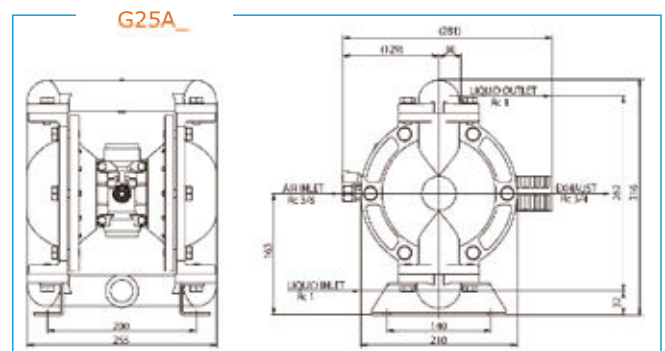
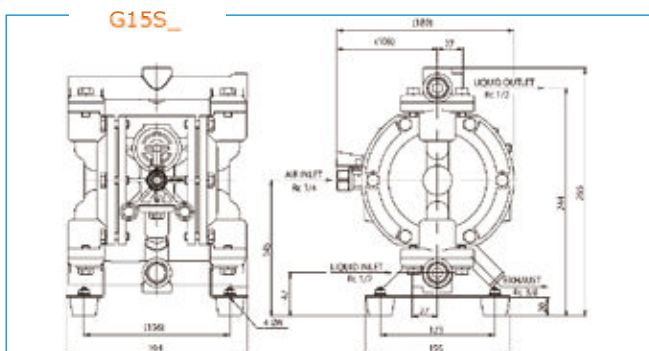
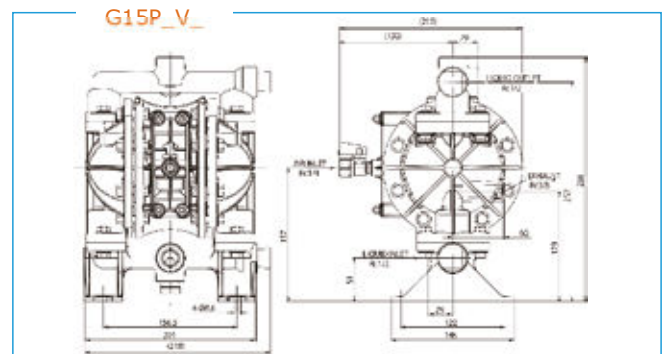
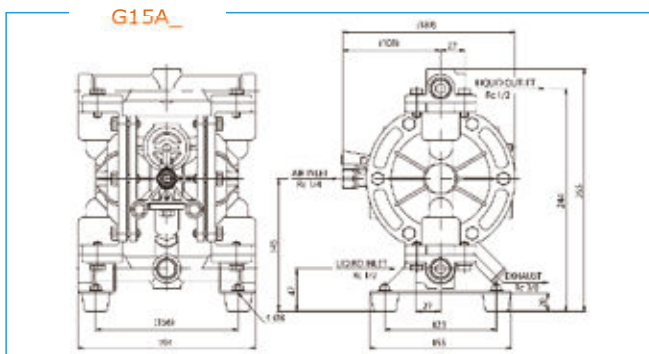

G15 GLOBAL SERIES

Maximum Capacity 62 l/min
Port Size 1/2" (15 mm)

GLOBAL SERIES
Air-Operated Double Diaphragm Pumps



G15 Aluminum

Dimensions: 194 mm W x 265 mm H
Net Wt.: 5,4 kg
Maximum Capacity: 58 l/min
*Buna N (NBR) diaphragm 60l/min

G15 Polypropylene
Dimensions:
218 mm W x 286 mm H
Net Wt.: 2,6 kg
Maximum Capacity: 62 l/min



G15 Stainless Steel
Dimensions:
194 mm W x 265 mm H
Net Wt.: 8,2 kg
Maximum Capacity: 56 l/min



G15 Kynar
Dimensions:
218 mm W x 286 mm H
Net Wt.: 3,5 kg
Maximum Capacity: 62 l/min



Please note:
The rubber feet are optional available for G15 Polypropylene and G15 Kynar.

G15 GLOBAL SERIES SPECIFICATIONS

Port Dimensions

Intake & discharge connection:	1/2" Female Rc
Air inlet (incl. ball valve):	1/4" Female Rc
Air exhaust (incl. silencer):	3/8" Female Rc

Air Supply Pressure (All Models)

2,0 – 7,0 Bar (0,2 – 0,7 MPa)

Discharge Volume Per Cycle

- G15A: 160 mL
- G15AN: 170 mL
- G15P/V: 190 mL
- G15S: 150 mL

Maximum Size Solid

1 mm or less

Maximum Suction Lift

Up to 2,0m

Air Motor

Aluminum air motor standard

The G15 series metal pumps are perfect for spraying and dispensing applications, particularly when on and off cycling reliability is critical. Utilizing our new Step Stool (S-spool), the G15 uses up to 30% less air than the competition. Maintenance friendly with fewer parts.

Model Number Nomenclature

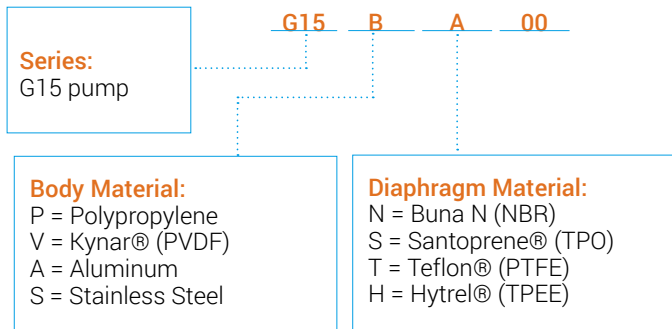

Note:

- G-serie always includes ball valves
- Santoprene® fitted pumps include EPDM wetted o-rings.
- Hytrel® fitted pumps include NBR o-rings

Polypropylene and PVDF Pump Performance Curve

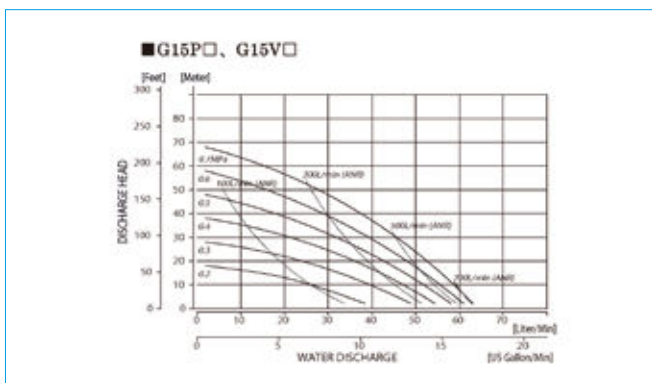

Aluminum Pump Performance Curve

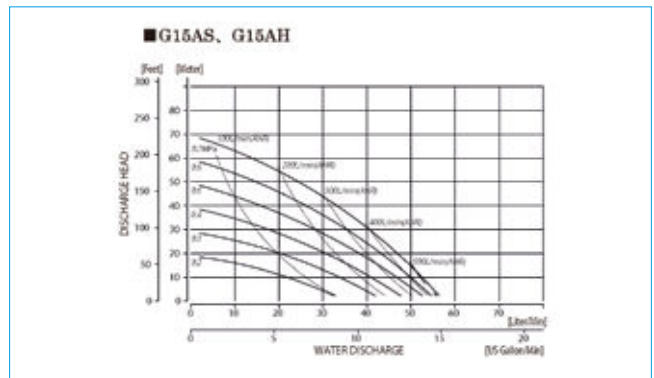
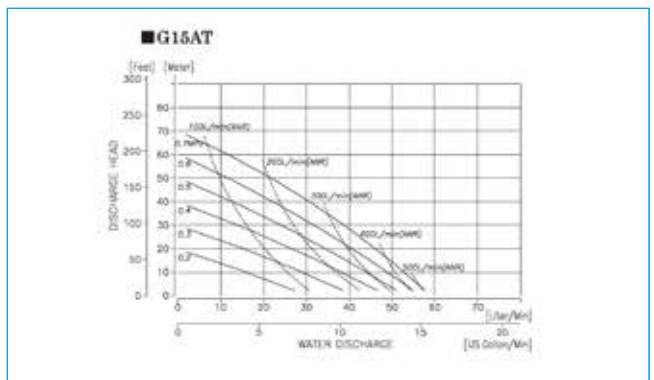
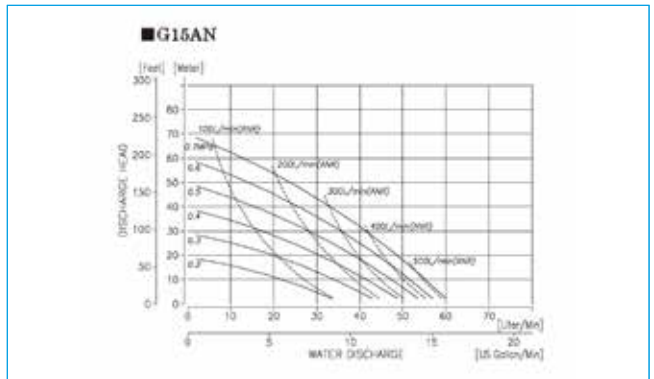

Stainless Steel Pump Performance Curve

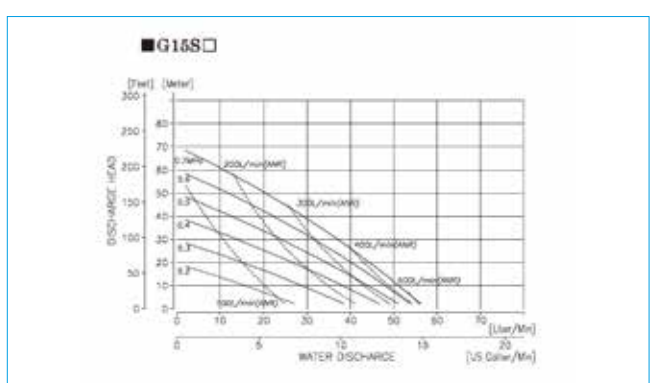

G25 GLOBAL SERIES

Maximum Capacity 150 l/min
Port Size 1" (25 mm)

GLOBAL SERIES
Air-Operated Double Diaphragm Pumps



G25 Aluminum

Dimensions: 255 mm W x 316 mm H

Net Wt.: 9,2 kg

Maximum Capacity: 150 l/min

*PTFE diaphragm 130 l/min

Please note:

The rubber feet are optional available for this pump.

G25 GLOBAL SERIES SPECIFICATIONS

Port Dimensions

Intake & discharge connection:

Aluminum (ADC-12)	1" Female Rc
Air inlet (incl. ball valve):	3/8" Female Rc
Air exhaust (incl. silencer):	3/4" Female Rc

Air Supply Pressure (All Models)

2,0 – 7,0 Bar (0,2 – 0,7 MPa)

Discharge Volume Per Cycle

Rubber diaphragm: 600 mL

PTFE diaphragm: 450 mL

Maximum Size Solid

3 mm or less

Maximum Suction Lift

Up to 3,0 m

Air Motor

Aluminum air motor standard on metal pumps

Valve Type

Ball

Model Number Nomenclature

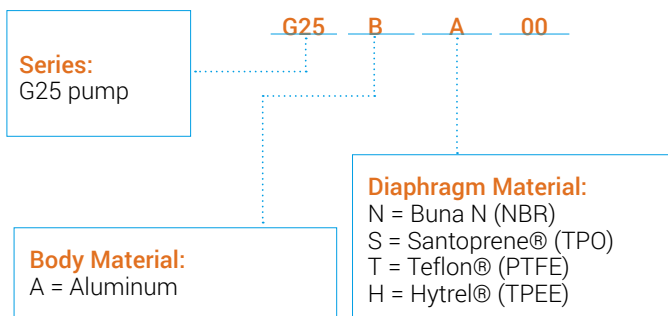

Note:

G serie always includes ball valves

Santoprene® fitted pumps include EPDM wetted o-rings.

Hytrel® fitted pumps include NBR o-rings

Performance Curve

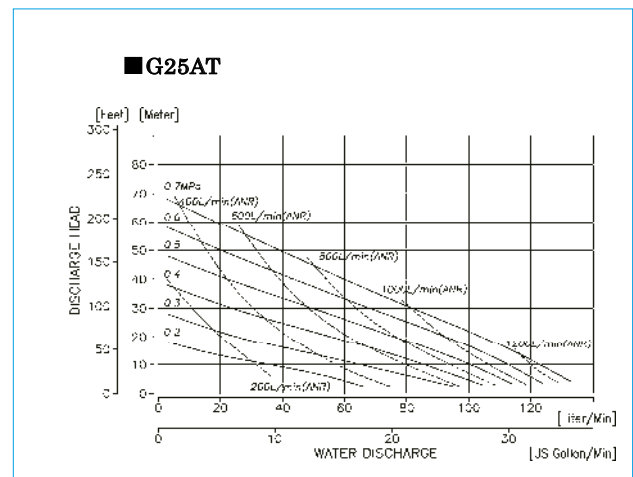
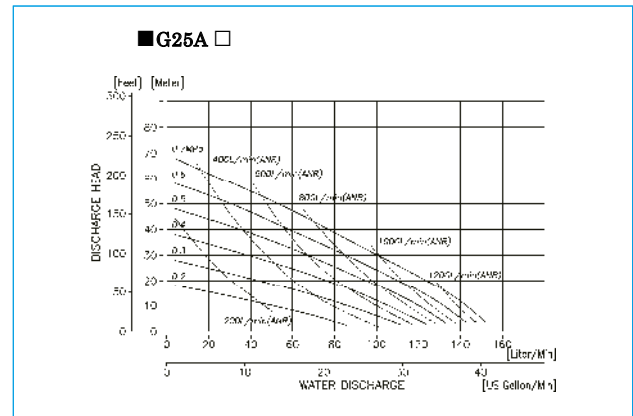

Dimensional Drawing

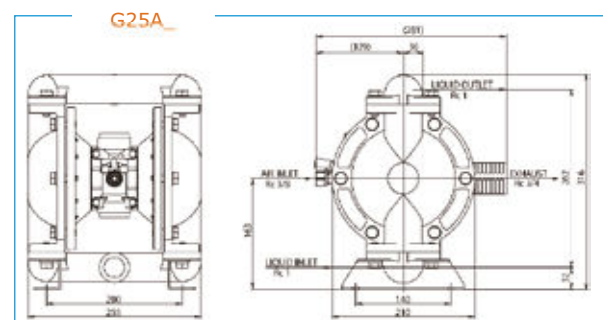



Model NDP-40 HP



Model NDP-25 HP

HIGH PRESSURE 2:1

2:1 Ratio High Pressure Pumps are designed for applications when a maximum 7 Bar operating pressure is insufficient to overcome system requirements. The flow rate is roughly half of the equivalent size pump output, though a maximum discharge pressure of 13 Bar can be achieved with only 7 Bar air inlet pressure supplied. The 2:1 discharge ratio is achieved by applying air pressure to the surface area of both diaphragms, doubling the discharge output.

Port sizes: 3/4"–3"
Construction

Capacity: 1 to 378 l/min
Stainless Steel, Cast Iron
or Aluminum wetted materials

Controls: No elaborate bypass, relief valves, or complicated controls required. Excellent pressure retention.

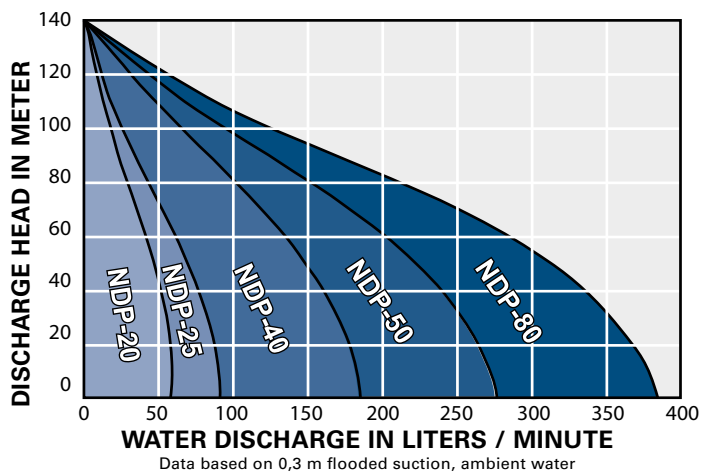

Model NDP-5FPT-Z



Model NDP-15BA-Z



Model NDP-15FP-Z



Model NDP-20BA-I

MANIFOLD OPTIONS

Many Yamada pumps come with a variety of multi manifold options offering the user various process solutions. Some options available are 2 in 1 out, 2 in 2 out, 1 in 2 out, vertical middle or side inlets etc. For more information on manifold options please contact Yamada or your local distributor.

Port sizes:

1/4", 3/8", 1/2", 3/4" and 1"

Construction

Polypropylene
Aluminium or Stainless Steel

Modes of operation

1/4", 3/8", 1/2", 3/4" and 1"

Construction

Stainless Steel, Cast Iron
or Aluminum wetted materials



Optional:
1" Rc inlet & outlet side ports. Available for aluminum 20 pumps only.



H-Series /XDP Pumps

XDP PUMPS (H-SERIES)

The Xtreme Duty Pro™ XDP, or our H-series, is designed for use in process type applications including filter press, high pressure, extended deadheading, long runs of discharge pipe and where air consumption is critical.

Air power is conserved by actuating the air valve using a mechanical linkage instead of relying on air pressure. Air power is reduced by 20% vs. A standard air-actuated valve providing more pressure to drive the diaphragm assembly.

Available in 1-1/2", 2" and 3" port sizes, these pumps are built on the liquid platform of a standard NDP Series pump, but with the world's only mechanically-actuated air motor.

Xtreme Duty Pro™ XDP pumps are capable of running on air pressure equivalents as high as 9 Bar or as low as 0,4 Bar and provide the same liquid side performance as the NDP Series pumps. The exception are the pumps with a PTFE diaphragm and/or a plastic pump body these have maximum of 7 bar. For additional information, product literature, and drawings please visit www.yamada-europe.com or contact your local Yamada distributor.



Model BH-3

POWDER PUMPS

Yamada® Powder Pumps were specifically designed to move bulk solids more effectively throughout your process. They are a cost effective replacement for Augers and Conveyors and eliminate unsafe and labor intensive means of moving bulk powders. These heavy duty pumps consistently transfer fine-grained (100um or finer), low bulk density (70 to 700kg / m³), dry powders in a dust-free operation.

Port sizes 1", 1-1/2", 2", or 3"

Construction Aluminum, Cast Iron, or Stainless Steel

Diaphragms CR, NBR

	Max. discharge volume
NDP-25	Approx. 200kg/hr
NDP-40	Approx. 500kg/hr
NDP-50	Approx. 1000kg/hr
NDP-80	Approx. 1500kg/hr

Extra options:

Reinforced center rod with bolted diaphragms
Y-manifold to optimize the flow.



Options

DRUM KITS

Yamada AODD Pumps have distinct design advantages, making them versatile and cost effective drum pumps. You can create your own drum pump with the help of the drum kits. These kits contain all the necessary parts (like bung lock, pipe, bushing, base plate or manifold) to convert a standard pump into a drum pump. The rebuilding process is simple and can be easily done by end users. All you need to do is to buy one of our pumps, plus one of the available kits.



^
FDA-Compliant Drum kits are available.



^
G15 DRUM PUMP

Please find in the table below the options, what the specific drum kits include and which parts are sold separately.

Yamada pump:	Drum kit model:	Bung	Bushing	Nipple	Thumb Screw	Pipe	Manifold	Clamp	Gasket	Coupling	Elbow	Base Plate	Mounting Bolts
DP-10 Aluminum	DP-10D	√	√	√	√	√	-	-	-	-	-	-	-
DP-10 Stainless Steel	DP-10SD	√	√	√	√	√	-	-	-	-	-	-	-
DP-10 FDA	DP-10SD-FDA	√	-	-	√	√	√	√	√	-	-	-	-
G15 Aluminum	G15AD	√	-	√	√	√	-	-	-	√	-	-	-
G15 Polypropylene	G15PD	√	√	√	√	√	-	-	-	-	-	√	√
NDP-15 Polypropylene	NDP-15PD	√	√	√	√	√	√	-	-	-	-	√	√
NDP-15 Kynar	NDP-15VD	√	√	-	√	√	*	-	-	-	√	-	-
NDP-15 Stainless Steel	NDP-15SD	√	-	√	√	√	√	-	-	√	-	-	-
NDP-20 Aluminum	NDP-20D	√	-	-	√	√	√	-	-	-	-	-	-
NDP-20 Polypropylene	NDP-20PD	√	√	-	-	√	-	-	-	-	√	-	-
NDP-20 Stainless Steel	NDP-20SD	√	-	-	√	√	√	-	-	-	-	-	-
NDP-20 FDA	NDP-20SD-FDA	√	-	-	√	√	√	√	√	-	-	-	-

* Sold separately



FDA Compliant
316 Stainless Steel

FDA COMPLIANT PUMPS

Yamada FDA compliant pumps are specifically designed for Food, Pharmaceutical & Cosmetic industries where 3A or USDA standards are not required.

Pumps include 316 Stainless Steel wetted components with passivated satin finish, teflon coated air motor, sanitary tri-clamp fittings, and FDA compliant elastomers: Hytrel®, EPDM, PTFE, PTFE coated Aluminum motor for sizes 10, 40, 50 and 80. PPS motor for sizes 5 and 15. PPG motor for sizes 20 and 25.

Eight sizes from 3/4" to 4" sanitary clamp connections

Flow ranges from 1 - 800 l/min

Air pressures ranging from 2,0 to 7,0 Bar

Air motor:

Aluminum Epoxy®-coated	DP-10, NDP-40/50/80
Ryton	NDP-5-15
Polypropylene (PPG)	NDP-20/25
PTFE coating for aluminum motor is possible as an option.	

Finish

Interior mechanical polish available on most models. Consult Yamada

Note:

FDA Series pumps are constructed with oversized sanitary ports.

ELECTRICAL CONTROLLED SERIES DM(B)(X)

Accurate flow control and measurement options. Less parts and extended life expectancy of moving parts including diaphragms. Low pressure movement (from 0,7 Bar) is possible in some cases. Unmatched start stop reliability, remote monitoring and control. Variable pump speed control. And many more.

Yamada's range of electrical controlled pumps with direct mounted 5/3 solenoid valves 24V DC are specially designed for process applications which require metering, batching or variable of constant flow control. These pumps offer extreme operation reliability, parts life time and a perfect balanced energy consumption. They are well suited to intense process applications. All DM(B)(X) pumps are operated through a locally positioned or remote PLC device (sold separately) and are available beside standard also as ATEX (X) approved in combination with the conductive pump materials such as metals, Kynar (PVDF) or Acetal.



DM(X) Series

Up till the NDP series 25, Yamada offers standard a DMB motor. The motor is specially prepared for direct mounting of the solenoid valves. The motors of NDP-5, 10 and 15 are made of a conductive plastic, which means they are suitable for an ATEX environment in combination with ATEX coils. For series 20, 23, 25 and 32 Yamada offers an aluminum DMB motor which of course can be protected with the well known high quality PTFE coating Yamada offers.

For series DP-10 and NDP-40, 50 and 80 we use special adaptor plates to mount the 5/3 solenoids, replacing the standard pneumatic valve house.

All pumps can be combined with a sensor for center rod movement detection, stroke or cycle counting, sensor shifting or in extreme situations for calibration. With cycle length calibration a PLC is able to use just a certain percentage of the cycle movement for fine dosing.

For more information, please contact Yamada or your local distributor.



FR(L)-UNITS

FR(L)-UNITS

Filter regulators provide precise air inlet pressure control and help optimizing pump performance and efficiency. FR-units protect pump diaphragms against excessive pressure. Besides that FR-unit filters the air and prevents airline contaminants from reaching your pump, providing a longer lifetime for the pump internals. For every pump size Yamada offers a special selected filter regulator for optimal performance.

Yamada NDP-series do not require lubrication, however for highly dry air applications all FR-units are available as FRL-unit. FRL-unit provides additional lubrication to the pump.

Features:

- Particle removal to 5 micron
- Analog pressure gauge
- "Locking" pressure control
- Automatic drain
- Mounting bracket
- ATEX conform



NDP-32BAN

NDP-32 SERIE

The NDP-32 series is a compact, lightweight and easily portable pump with a 1-1/2" liquid inlet and a 1-1/4" vertical outlet. This model corresponds in both footprint dimensions, body size and outlet positions to many pumps used in the marine, oil & gas and mining applications throughout the world. This size pump is often used for waste water or sump / mine dewatering applications and has the ability to pump solid laden slurry solutions. The body is in aluminium with Buna-N diaphragms however can also be prepared with other materials if required. Due to the dimensional standardization it is possible to carryout hard piped pump changeovers without having to modify the piping or system configuration.

Pump model is available in aluminum

Inlet 1-1/2" NPT Outlet 1-1/4" RC *

Air supply pressure 2,0 – 7,0 Bar

* NPT connection is also possible as an option.

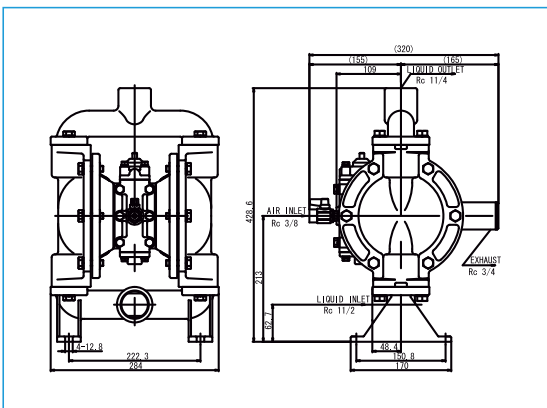

CONNECTION TYPES

For Yamada pumps we offer several connection types. Standard threaded connection at Yamada Europe is the RC-connection (BSPT).

Other available on request threaded connections are NPT and BSP. Besides that we offer flanged connection options FLG (DIN) or FLGA (ANSI) on request instead of threaded connections. Yamada 2" and 3" Aluminum and Stainless Steel pumps have universal flanged connections, which are equivalent both to DIN and ANSI.



CONNECTION FLG FLANGE + THREAD

MUFFLER OPTIONS

Yamada Europe offers multiple muffler options to reduce the pump's noise level. Yamada's standard muffler range is based on pump sizes and pump materials. Internal mufflers for the pumps up to size NDP-15. Plastic and metal mufflers for pump sizes starting with NDP-20.

Besides of the standard mufflers Yamada also offers:

- High performance muffler, which provides better noise protection and can be used in the extremely contaminated environments.
- Low noise double muffler, which is a good and economical solution for extra noise reduction.
- Speed control muffler, which you can use to adjust the pump speed.



MUFFLERS



SOLIDS HANDLING PUMP

Flap Valve Pump designed to pump large solids

The Yamada Flap Valve Pump was designed and engineered to address the problems normally associated with flap valve pumps. I.e. Normally due to severe working conditions, there is often a need to remove a pump from service for repairs, cleaning or parts changeovers.

Based on Yamada field proven NDP series foundation, this pump has all of the features and benefits associated with every Yamada pump.

Ingenious Flap Valve design allows for passage of large solids up to a maximum size solid of Ø 30 mm for spherical solids and a maximum between Ø 15-45 mm cylindrical solids.

Easy access to valve chambers allows easy maintenance when you need it most without the need to remove the pump from service.

Vented diaphragm chambers serve to alleviate problems associated with trapped air/gas.



NDP-50FAN

FEATURES AND BENEFITS

- Repair/clean in place design enables quick servicing of pump
- Handling up to Ø 30 mm spherical solids and Ø 15-45 mm cylindrical solids.
- Vent ports to alleviate build-up of air/gas in liquid chamber
- Quick removable flap valves
- Top suction, bottom discharge design will not allow solids to settle in pump.
- Fully non lubricated Air-Valve
- Fully bolted construction
- Short stroke design to help improve diaphragm life.
- Outside-Accessible Air Valve
- Modular Pilot valve design
- No dynamic O-rings to replace or repair.



Repair/clean in place design



Only 4 bolts to access flap valves

Modular Heavy Duty Flap Check Valves



Vent ports to alleviate vapour lock and help with priming



LIQUID LEVEL CONTROLLER

The Yamada LLC-2Y Liquid Level Controller is a totally pneumatic system designed to automatically start and stop Yamada Air-Powered Double Diaphragm Pumps when the liquid level within a tank, sump, etc. reaches predetermined levels.

An extremely versatile controller, the LLC-2Y can be used in both single and dual pump applications with any size or model Yamada pump. Used in a single pump configuration, it automatically controls either the filling or emptying of a tank or other vessel. When connected to two separate pumps, it will control both the filling and emptying of the tank. This dual pump capability is particularly useful for waste water storage, contaminated water clean up, and other applications where liquids are regularly transferred into and out of a single vessel.

The LLC-2Y consists of a sophisticated air logic control valve housed in an impact-resistant fiberglass reinforced plastic enclosure. As the liquid level within the tank rises or falls, the subtle changes in pressure are transmitted through high and low level dip tubes to the air logic control valve. When the liquid level reaches a predetermined level (tubing is cut in the field to the preferred HIGH and LOW level points), the power valve supplying air pressure to the pump is turned ON or OFF as required.

The LLC-2Y is capable of maintaining liquid levels in virtually any unpressurized vessel. Its liquid level control span ranges from a few inches to dozens of feet. For added convenience, it may be mounted up to 6 meter away from the pump.



DRY-RUN DETECTION

DRD-100 Dry-Run Detector

The Yamada DRD-100 detects increases in air volume due to loss of prime or dry-running, and automatically shuts down the pump to prevent excess cycling and increased diaphragm wear.

Extends life of diaphragm

Eliminate air consumption in dry run applications

Prevents air valve from premature failure

Intrinsically safe operation

Supports remote warning systems

PULSATION DAMPENERS



Model AD-10

AD Series

Metering/Injection/Dosing

Equalizes discharge pressure spikes, increasing accuracy.

Filter Press/Inline Filters

Increases filter efficiency and life by providing a smooth flow. Spraying: Smooth, consistent spray pattern.

Filling

Eliminates inconsistent filling and splashing.

Transfer

Eliminates harmful water hammer, preventing pipe and valve damage. Yamada Pulsation Dampeners incorporate a flow-through design which keeps solids in suspension, maintaining dampener effectiveness.

A completely automatic air motor self-relieves if reduction of discharge head condition occurs.



Model AD-25

Dampener Model

Fits Pump Models

AD-10	NDP-5, DP-10/15, & NDP-15
AD-25	NDP-(P)20 & NDP-(P)25
AD-40	NDP-40
AD-50	NDP-(P)50 & NDP-80

Model AD-40



Dampener Model

Connections

AD-10	3/8" Rc port
AD-25	1" Rc port
AD-40	1-1/2" Rc port
AD-50	2" Rc port

Material

Aluminum (ADC-12)	All models
Stainless Steel (316)	All models
Cast Iron	AD-25, AD-40, & AD-50
Polypropylene (PPG)	All models
Kynar® (PVDF)	AD-25, AD-40 & AD-50

Diaphragm

Choice of seven elastomers: Santoprene®, Hytrel®, Buna N, EPDM, Neoprene, Viton® & PTFE

Air Side Coating Options

Teflon®, or Electroless-Nickel plate air-side

For additional information, product literature, please visit www.yamada-europe.com or contact your local Yamada distributor.



Model AD-50

Without Pulsation Dampeners

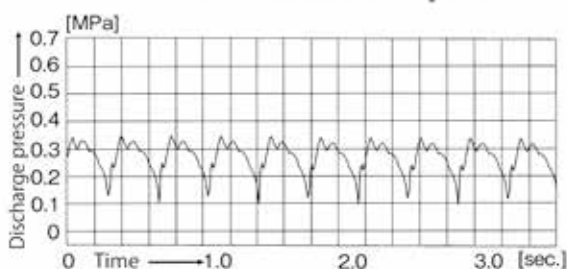

With Pulsation Dampeners

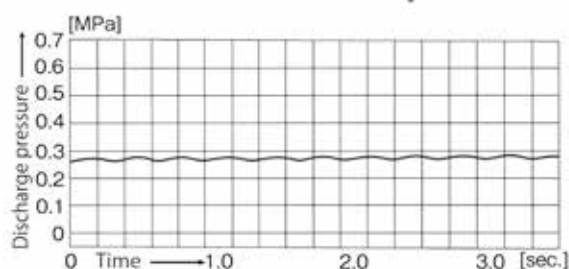



Rubber Compounds

Neoprene (CR)

Excellent for non-corrosive abrasive applications.
 Identification: dull black with no color dot
 Temperature range: -20°C to 82°C

Buna-N (NBR)

Excellent for petroleum based fluids.
 Identification: black with a red or pink dot
 Temperature range: -20°C to 82°C

Nordel™ (EPDM)

Excellent for low temperatures, caustics and some acids.
 FDA Compliant EPDM Material (must be specified).
 Identification: black with green dot
 Temperature range: -20°C to 100°C

Viton® (FKM)

Excellent for aggressive fluids and high temperature applications.
 Identification: black with silver or blue dot
 Temperature range: -5°C to 105°C



The TU diaphragm has a rod connection only at the air side and an easy to clean liquid surface. This means no ink or paint residue will accumulate behind bolts, center disks etc. which prevents color contamination. Temperature Range: -10°C to 90°C.

* Please note that excessive inlet pressure or excessive suction lift can shorten diaphragm life. Please consult Yamada for further information.

PUMP DIAPHRAGMS

What to consider when selecting the proper diaphragm material

- Chemical resistance
- Estimated flex life
- Temperature limitations
- Abrasion resistance
- Cost

Also beside the correct diaphragm, the correct pump material must be selected, being chemical, temperature and abrasive resistant.

Thermoplastic Compounds

Hytrel® (TPEE)

Excellent general-purpose diaphragm for non-corrosive abrasive applications and high-flex life. FDA compliant material.
 Identification: Tan/Cream Thermoplastic
 Temperature Range: -30°C to 82°C

Santoprene® (TPO)

Excellent for acids or caustics with a very high flex life.
 Identification: Black Thermoplastic
 Temperature Range: -20°C to 100°C

Teflon® (PTFE)

Excellent choice for pumping highly aggressive fluids, including solvents.
 Identification: White Thermoplastic
 Temperature Range: 0°C to 100°C

Ultimate Teflon bonded Diaphragms

TU® (PTFE/EPDM)

This so called high performance easy clean PTFE diaphragm has earned its reputation already in the ink, paint and printing industry for more than 15 years. In this 24/7 industry the diaphragm has proven its reliability. This high flexible PTFE diaphragm has a much better estimated life time compared to standard PTFE diaphragms. Standard diaphragms have thread, nuts and center disks inside the liquid area.

MIN/MAX FLUID TEMPERATURE TO PUMP

For metal pumps it is dictated by the elastomer diaphragm material.
 For the synthetic pumps, it depends.

Pump Material	Code	Material temp		Process temp		Diaphragm Material	Code	Material temp		Process temp	
		Min °C	Max °C	Min °C	Max °C			Min °C	Max °C	Min °C	Max °C
Polypropylene reinforced (PPG)	BP./FP.	0	- 70	0	- 60	Neoprene (CR)	C	-20	- 82	0	- 70
Conductive Delrin® (POM)	FDT	-7.5	- 82	0	- 60	Nordel™ (EPDM)	E	-20	- 100	0	- 80
Conductive Kynar® (PVDF)	BV./FV.	-15	- 100	0	- 60	Hytrel® (TPEE)	H	-30	- 82	0	- 80
Teflon® (PTFE)	T	0	- 100	0	- 100	Buna-N (NBR)	N	-20	- 82	0	- 70
						Santoprene® (TPO)	S	-20	- 100	0	- 100
						Teflon® (PTFE)	T	0	- 100	0	- 100
						Ultimate Teflon® (TU®)	TU®	-10	- 90	0	- 90
						Viton® (FKM)	V	-5	- 105	0	- 100



OPTIONAL COATING ALUMINUM AIR MOTOR

Teflon® coating is available for Yamada pumps for two primary reasons:

Environment: Pump installation in a chemically aggressive location where material or fumes not compatible with Aluminum may contact the air motor; or

Diaphragm Failure: If properly selected, the coating will defend the major Aluminum air valve components from the fluid being pumped. For internal and external protection, the four major air motor components are independently coated then assembled.



Teflon® Coating

IDEAL AIR-POWERED DOUBLE DIAPHRAGM PUMP INSTALLATION

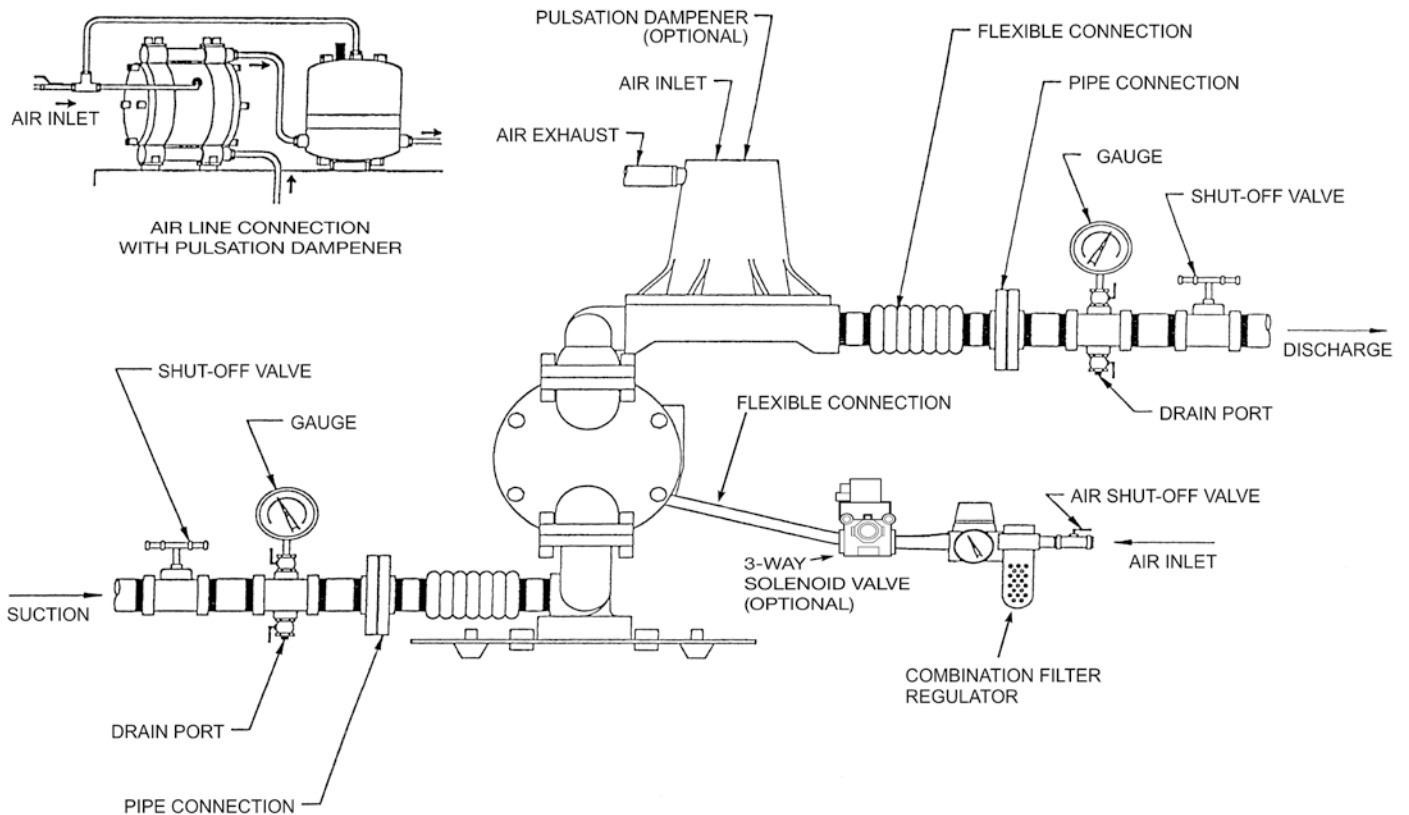

ADDITIONAL OPTIONS

Model Number Nomenclature

XXX - X XX X X X - X

PUMP SERIES;
NDP / DP

MOTOR (OPTION)

CONNECTION SIZE

CHECK VALVE TYPE

BODY MATERIAL

DIAPHRAGM
MATERIAL

C:	CR	NEOPRENE
E:	EPDM	NORDEL™
H:	TPEE	HYTREL
N:	NBR	BUNA-N
S:	TPO	SANTOPRENE®
T:	PTFE	TEFLON®
TU®:	PTFE/EPDM	
V:	FPM	VITON®

A:	ALUMINUM
S:	SCS14
F:	CAST IRON
P:	PPG
D:	DELTRIN
V:	PVDF KYNAR
T:	PTFE TEFLON®

B:	BALL VALVE
F:	FLAT VALVE NDP-5 NDP-15 PLASTIC
F:	FLAP VALVE 50FAN

5:	1/4"	12 l/min
10:	3/8"	22 l/min
15:	1/2"	51 l/min
20:	3/4"	120 l/min
25:	1"	170 l/min
32:	(in) 1,5" (out) 1,25"	190 l/min
40:	1,5"	405 l/min
50:	2"	620 l/min
80:	3"	814 l/min

Motor (option)

P:	PPG motor, size P20, P25 and P50 (=standard all PPG pumps 20, 25 and 50)
H:	XDP motor, size H40, H50 and H80 (see page 33)

To properly specify a Yamada pump, the following information is required.

- Material to pump
- Viscosity
- Density
- Particle size
- Required capacity L/min
- Corrosive
- Abrasive
- Temperature
- Available air pressure
- Application details like: Diameter, length, height, depth etc. all fluid lines.

Yamada sales team and your distributor are there to help you, choosing the best and most cost effective pump solution.

Yamada®, SolidPRO®, Xtreme Duty Pro™ XDP are registered trademarks of Yamada America, Inc
Hytrel® & Teflon® are a registered trademarks of E.I. du Pont de Nemours and Company.
Kynar® is a registered trademark of Arkema.
Nordel™ is a registered trademark of Dupont Dow Elastomers.
Ryton® is a registered trademark of Chevron Phillips Chemical Company.
Santoprene® is a registered trademark of Monsanto Co.
Viton® is a registered trademark of Dupont Performance Elastomers

Special Pumps:

- BH3: Powder pumps NDP-25 until 80 metal
- P: Reinforced rod + bolted diaphragms
- Y: Y-manifold stainless steel NDP-40, 50, 80
- HP: High pressure 2:1 pump metal 20 until 80
- D: Drum pump until size 20
- FDA: FDA compliant series

Additional Options

Ball Options

- NBR: Ball-N
- E: Nordel™
- S: Santoprene®
- T: Teflon® ball
- V: Viton® ball
- S1: Stainless steel ball (until size 50)
- Stainless steel flat (NDP-5/15)

Valve seat Options

- T2: Teflon® (only NDP-40 and 50)
- AL2: Aluminum seat (only NDP-40 and 50)
- V2: Viton®
- S2: Stainless steel machined seat

Combi SUS ball/seat/guide:

- S3: Stainless steel guide (until size 25)
- SS: Stainless steel seat + ball (S1 + S2)
- ST: Stainless steel seat + guide (S2+S3)
- ST1: S1 + S2 + S3

Connection options:

- I: Split inlet manifold (Double in)
- O: Split outlet manifold (Double out)
- Z: Double in and out
- I, O and Z only until size 25
- FLG: DN flange connection ≥ size 15
- FLGA: ANSI flange connection ≥ size 15
- NPT: NPT female thread connection

Air Motor options:

- XS: PTFE coated aluminum motor

Electrical control options:

- P2: Proximity sensor
- PX: Proximity sensor ATEX
- RM: Electr. on/off solenoid 24VDC
- RMX: Electr. on/off solenoid 24VDC ATEX
- DM: Full solenoid control 24VDC
- DMX: Full solenoid control 24VDC ATEX+ (DM(X) DP-10, NDP-P20/P25, 40, (P)50 and 80)
- DMB: Full solenoid control 24VDC
- DMBX: Full solenoid control 24VDC ATEX (DMB(X) for NDP-5, 15, 20, 23, 25, 32)
- Q: Leak sensor(s) (Diaphragm rupture)

Specific options:

- 1: PTFE O-rings
- 1S: 1" side connection NDP-20BA
- N: Special bearing dry air
- XPS: Xtreme duty C-spool NDP-20/25
- ZA: Aluminum pilot valve NDP-40+50

Accessories options:

- AP: Abrasion PAD
- J: Speed control muffler
- L: De-stroke NDP-20 until 80

For more ADD ON options, please contact Yamada or your local distributor.



Due to Dutch, European and international trade laws, Yamada-products may require licensing prior to export or re-export. We request that when dealing with Yamada-products that you take the utmost care in ensuring that all required legal procedures are carried out correctly.

Your Local Distributor/Sales & Service Centre:



Ref Nr.: EN0524



Yamada Europe B.V.

Aquamarijnstraat 50 • 7554 NS Hengelo (OV) • The Netherlands

Phone: +31 (0)74-242 2032 • E-mail: sales@yamada-europe.com